



**Waukesha
Cherry-Burrell**

UNIVERSAL I

SERIES

PUMPS

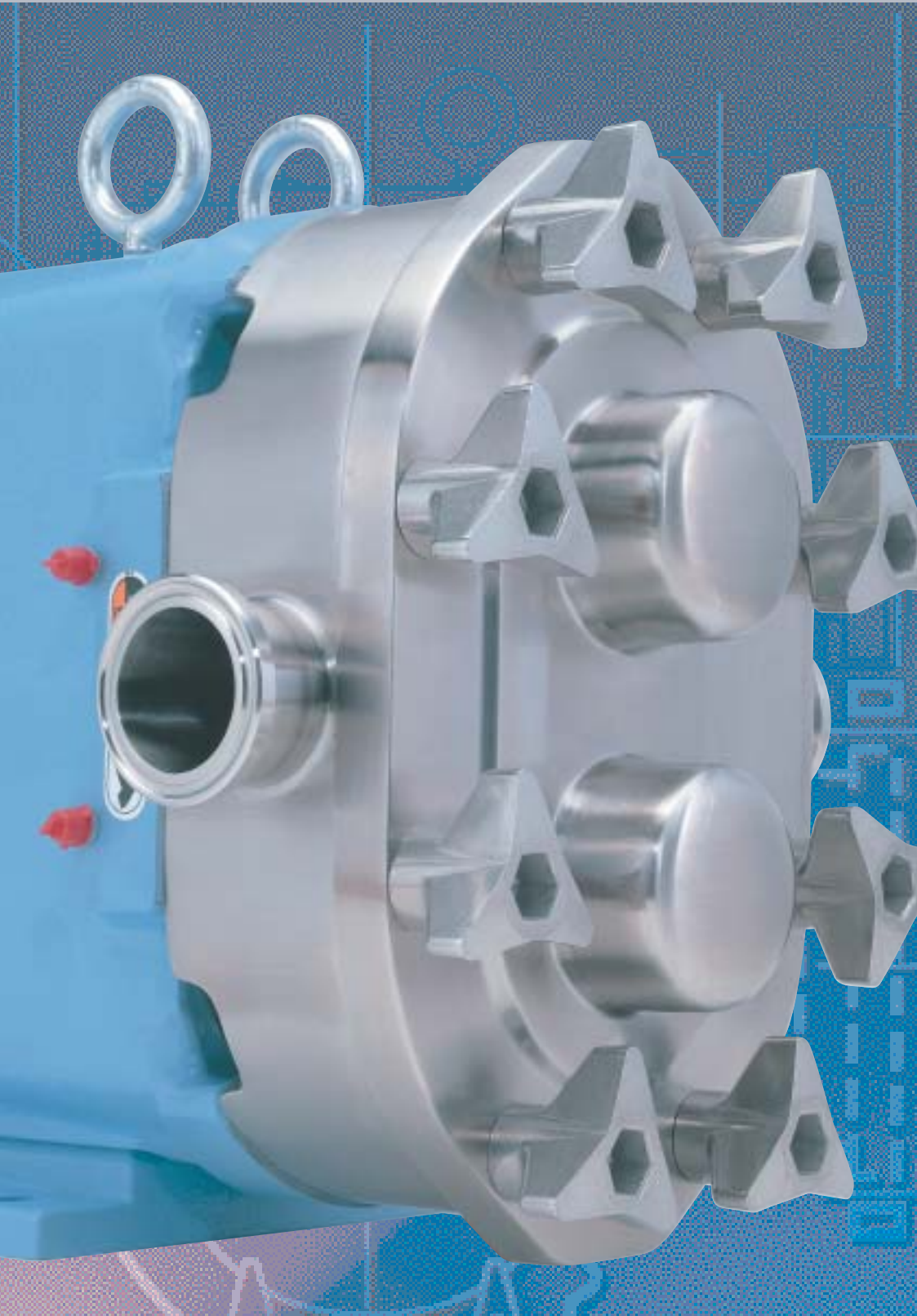

ROTARY POSITIVE DISPLACEMENT PUMPS

Setting the standard of performance for the sanitary industry for over 50 years.

For more than half a century, Waukesha Cherry-Burrell has been a leader in the design, manufacturing and application of external circumferential piston (ECP) style, rotary positive displacement pumps. Waukesha Cherry-Burrell PD pumps are in service around the world in food, dairy, canning, bakery, beverage and pharmaceutical processing, as well as challenging chemical and industrial applications.

Users of Waukesha Cherry-Burrell PD pumps benefit from decades of continuing product improvement. Steady advances in design, metallurgy and fabrication techniques have yielded progressively higher levels of performance and service life.

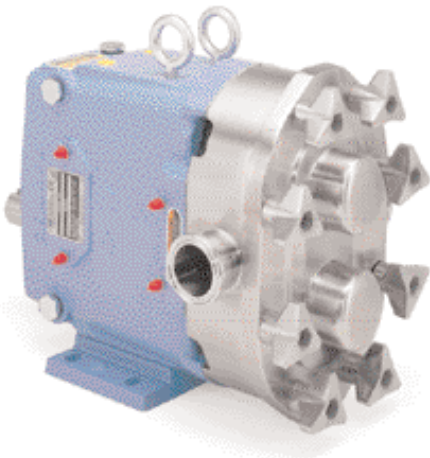

Sanitation features

- **316 stainless steel body, cover, and shaft.**
- **Easy disassembly** for COP cleaning.
- **Elastomers** that comply with FDA requirements.
- **Aseptic** models available.
- **Meets 3A sanitary standards.**

Long-life features

- **200 (13.8 bar) psi pressure capability.***
- **No bearings in product zone.**
- **Heavy duty bearing frame** with large diameter shafts.
- **Grease lubed bearings** for positive lubrication of all bearings over entire speed, temperature and pressure range.
- **Exclusive, non-galling Waukesha “88” alloy rotors standard;** permits running at tighter clearances and pumping a wide range of viscosities.
- **Remanufacturing** and **Inspect and Advise** programs to extend life and reduce costs.

Available options

**High strength 17-4 PH shafts and hex cover nuts for higher pressure applications.*

- **Stainless steel gear case.**
- **Stainless steel bearing retainers (NEW).**
- **Bearing isolators** protect bearings from contamination **(NEW).**
- **Body retaining screws (NEW).**
- **Steel-It paint (NEW).**
- **Single wing rotors** for minimum damage of particulates.
- **Jacketed or vented covers.**
- **Rectangular flange** inlet for high viscosity products.

Universal I Series



Shown with optional stainless steel gearcase

Installation flexibility

- **Bi-directional flow.** Rotors, locked with double jam nuts, rotate securely in either direction. No flow direction/shaft position specifications.
- **Versatile 3-Way mounting** of gear case, including vertical alignment of ports.
- **Upper or lower shaft position.**
- **Easy to install or convert** between single or double o-ring or mechanical seals.
- **Interchangeable installation dimensions** with Universal II and Universal Lobe PD pumps.



Typical product applications

Bakery

Batters
Flavorings
Frostings
Fruit Fillings
Fats & Oils
Sweeteners
Yeast Slurry

Beverage

Beer, Wort, Yeast
Soft Drinks
Juice
Fruit Concentrates
Fruit Drinks
Wine
High Fructose Corn Syrups (HFCS)

Canning

Baby Foods, Soups, Stews
Tomato Paste/Sauces
Fruit Puree
Vegetables, Diced, Slurries
Puddings, Jams, Jellies
Salad Dressings, Mayonnaise

Confectionery

Syrups
Cream Fillings
Chocolate

Cosmetics

Face Creams & Lotions
Hair Styling Gels & Liquids
Essential Oils
Dyes & Alcohols
Shampoos

Dairy

Cream, Milk, Butter
Cheese Curd & Whey
Cottage Cheese
Yogurt

Meat Packing

Meat-Emulsions
Ground Meats
Pet Foods
Ruffle & Caul Fat
Mechanically Deboned Meat (MDM)

Pharmaceutical/Health Care

Pill Pastes
Syrups
Extracts
Emulsions
Slurries
Tooth Paste

Aseptic

Tomato Pastes
Puddings

Universal I Series

Time-tested Waukesha Cherry-Burrell Rotary Pump.

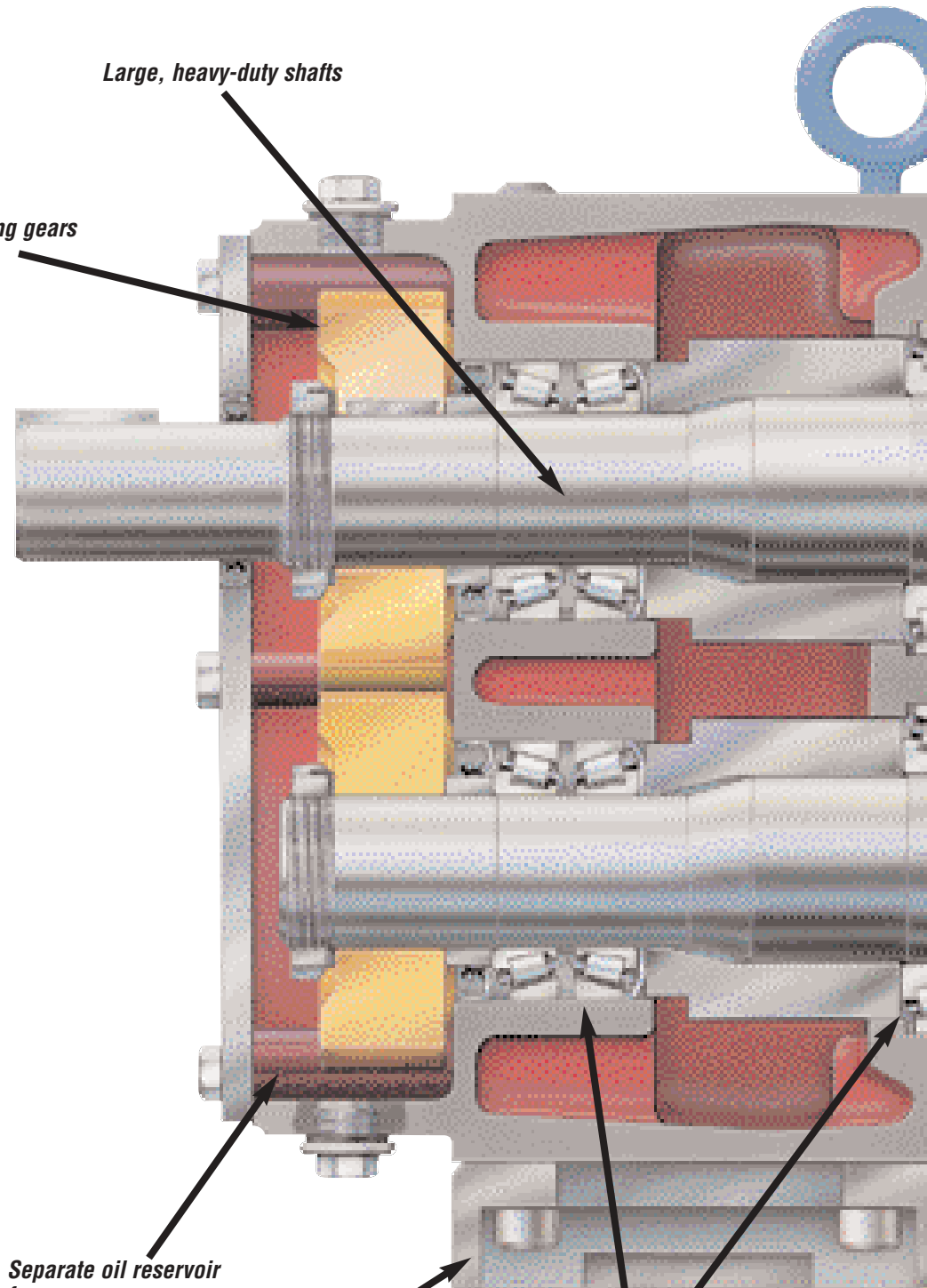

The Waukesha Cherry-Burrell
Universal I Series gives you...

High pressure capability;
200 psi/13.8 bar*.

Long service life: High capacity
components for long trouble-
free service.

The right seal for every
application, plus easy
interchangeability when needed.

Metal rotor: Waukesha "88"
non-galling alloy, for close
running clearance.

*For higher pressures, consult the factory.

Separate oil reservoir
for gears

3-way mounting gear
case standard

High-capacity, double
tapered roller bearings;
no adjustment needed
Pre-set assemblies high
capacity ball bearings on
Models 6, 15, 18 & 30

Seal Options

FIELD INTERCHANGEABLE SEAL options for every service. Compact design keeps shaft length to a minimum.

316 stainless steel body and cover; design conforms to 3A, USDA, BISSC, ASME standards

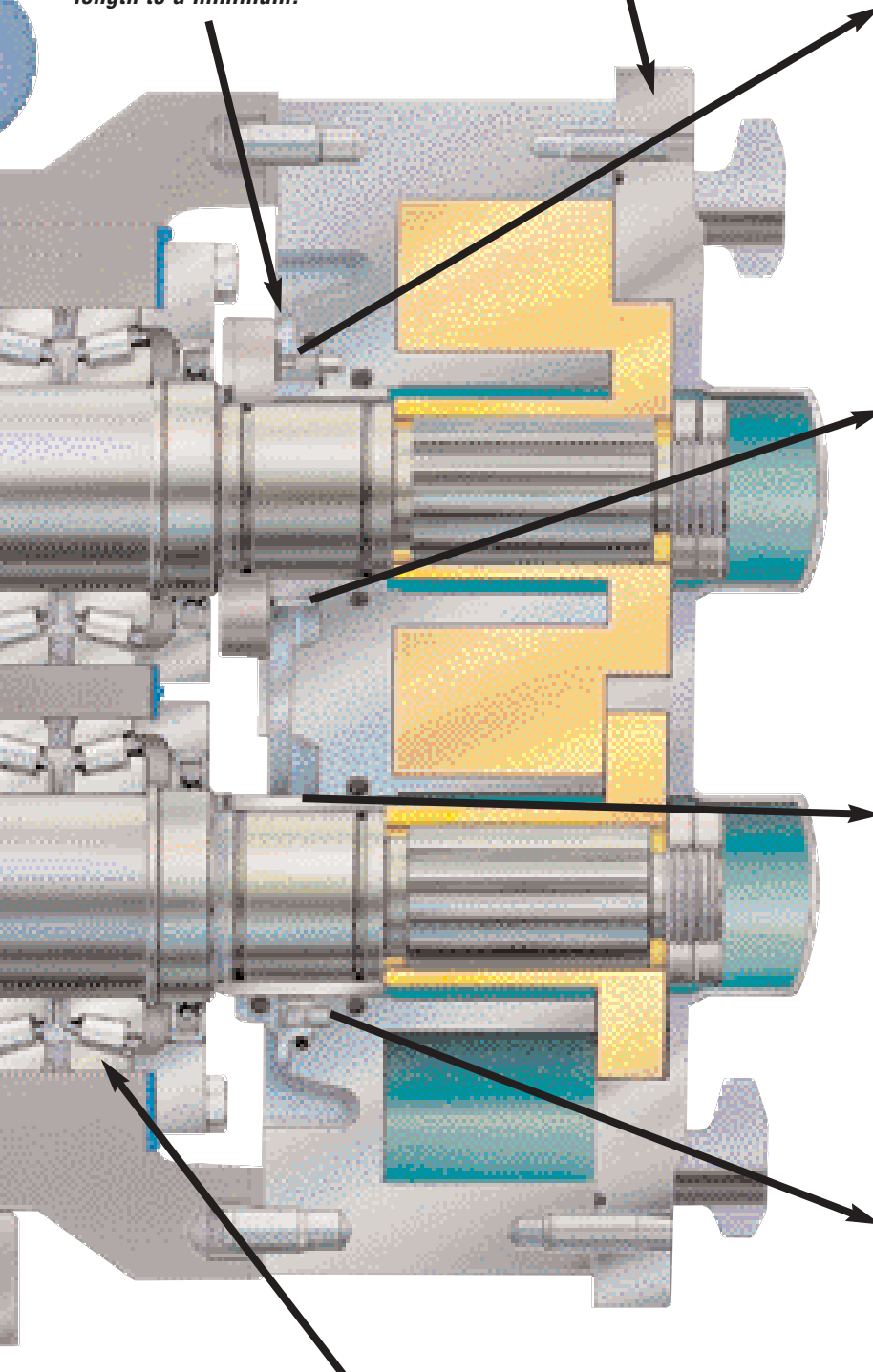

Front bearing fixed; rear bearing floating. Better control of thermal expansion when handling hot products

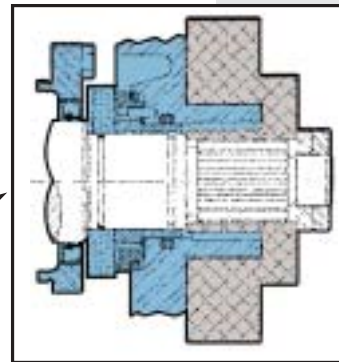

Double Concentric Mechanical Seal[†]

Used with flushing fluid to cool, lubricate, flush away residue. Best arrangement for severe service.

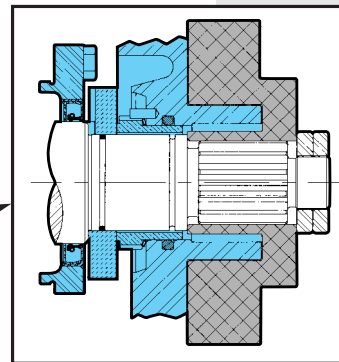

Single Mechanical Seal[†]

Longer life, wider pressure-temperature, and speed range than O-ring seal. Carbon-to-ceramic faces standard. Alternate materials available for abrasive service.

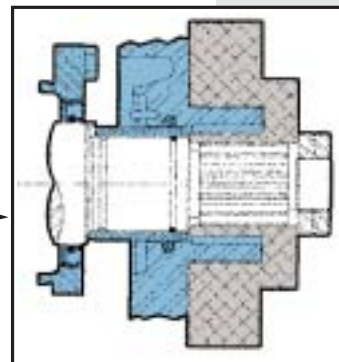

"O" Ring Seal*

Waukesha Cherry-Burrell's traditional general purpose seal. Low cost service components.

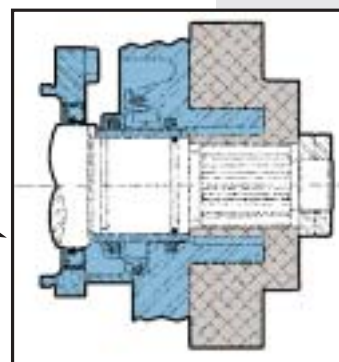

Double "O" Ring Seal*

The double, flushed version of the "O" ring seal. Used with flushing fluid to cool, lubricate, flush away residue.

Elastomer choices for "O" rings:

- Buna-N
- Fluorocarbon
- EPDM
- Silicone
- PTFE Encapsulated
- Kalrez®

*Not available for model 320

[†]Mechanical seal material options:

- Carbon
- Ceramic
- Chrome Oxide
- Silicon Carbide

Universal I Series Specifications

Universal I Models

MODEL	DISPLACEMENT PER REVOLUTION	NOMINAL CAPACITY* TO	INLET/OUTLET	OPTIONAL INLET/OUTLET	PRESSURE RANGE UP TO**	MAXIMUM RPM	TEMP RANGE**
006-U1	.0082 GAL. (.031 LITER)	6 GPM (1.3 m ³ /hr.)	1"	1½"	200 PSI (13.8 bar)	800	(-)40PF /C to 300PF (149PC)
015-U1	.0142 GAL. (.054 LITER)	9 GPM (2.0 m ³ /hr.)	1½"	–	200 PSI (13.8 bar)	700	
018-U1	.029 GAL. (.110 LITER)	17 GPM (3.8 m ³ /hr.)	1½"	2"	200 PSI (13.8 bar)	600	
030-U1	.060 GAL. (.227 LITER)	36 GPM (8.2 m ³ /hr.)	1½"	2"	200 PSI (13.8 bar)	600	
060-U1	.153 GAL. (.579 LITER)	90 GPM (20.4 m ³ /hr.)	2½"	3"	200 PSI (13.8 bar)	600	
130-U1	.254 GAL. (.961 LITER)	150 GPM (34.1 m ³ /hr.)	3"	–	200 PSI (13.8 bar)	600	
220-U1	.522 GAL. (1.976 LITER)	310 GPM (70.4 m ³ /hr.)	4"	–	200 PSI (13.8 bar)	600	
320-U1	.754 GAL. (2.854 LITER)	450 GPM (102 m ³ /hr.)	6"	–	200 PSI (13.8 bar)	600	

Rectangular Flange Models

MODEL	DISPLACEMENT PER REVOLUTION	NOMINAL CAPACITY TO	INLET W x L INCHES	OUTLET	PRESSURE RANGE UP TO**	MAXIMUM RPM	TEMP RANGE**
014-U1	.0142 GAL. (.054 LITER)	5 GPM (1.1 m ³ /hr.)	1.5 x 4.75	1½"	200 PSI (13.8 bar)	400	(-)40PF /C to 300PF (149PC)
024-U1	.029 GAL. (.110 LITER)	11 GPM (2.5 m ³ /hr.)	1.31 x 4.93	1½" (2")	200 PSI (13.8 bar)	400	
034-U1	.060 GAL. (.227 LITER)	24 GPM (5.4 m ³ /hr.)	1.75 x 6.75	2"	200 PSI (13.8 bar)	400	
064-U1	.153 GAL. (.579 LITER)	60 GPM (13.6 m ³ /hr.)	2.24 x 8.82	2½" (3")	200 PSI (13.8 bar)	400	
134-U1	.254 GAL. (.961 LITER)	100 GPM (22.7 m ³ /hr.)	2.97 x 9.25	3"	200 PSI (13.8 bar)	400	
224-U1	.522 GAL. (1.976 LITER)	200 GPM (45.4 m ³ /hr.)	3.87 x 11	4"	200 PSI (13.8 bar)	400	
324-U1	.754 GAL. (2.854 LITER)	300 GPM (68.1 m ³ /hr.)	5 x 17.38	6"	200 PSI (13.8 bar)	400	

Aseptic Models

MODEL	DISPLACEMENT PER REVOLUTION	NOMINAL CAPACITY* TO	INLET/OUTLET	PRESSURE RANGE UP TO	MAXIMUM RPM	TEMP RANGE**
033A	.051 GAL. (.193 LITER)	30 GPM (6.8 m ³ /hr.)	1½"	225 PSI (15.5 bar)	600	(-)40PF /C to 300PF (149PC)
133A	.205 GAL. (.776 LITER)	120 GPM (27.3 m ³ /hr.)	3"	225 PSI (15.5 bar)	600	
223A	.440 GAL. (1.666 LITER)	260 GPM (59.1 m ³ /hr.)	4"	225 PSI (15.5 bar)	600	
323A	.616 GAL. (2.332 LITER)	360 GPM (81.8 m ³ /hr.)	6"	225 PSI (15.5 bar)	600	

*For capacities above 450 to 935 GPM, see bulletin FH-1725 on 420/520 UHC (ECP Rotors) and FH-1733 on 420/520 UHCL (Lobe Rotors).

**Contact application engineering for higher pressure or higher temperature applications.

Note: Universal II (Bulletin FH-1723) and Universal Lobe (Bulletin FH-1733) models are available for CIP installations, applications up to 500 psi, and extended run services not needing frequent teardown for cleaning.

Time-tested Waukesha Cherry-Burrell rotary pump; external circumferential piston (ECP) operating principle

In the Waukesha Cherry-Burrell design, arc-shaped “pistons” (rotor wings) travel in annular-shaped cylinders machined in the pump body; the resulting long sealing path reduces slippage and produces a smooth flow of product without destructive pulses or pressure peaks and without valves or complex parts.

Exclusive Waukesha Cherry-Burrell design features

For Low Viscosity Fluids, rotors, made of exclusive Waukesha “88” alloy, can be run with close clearance to the 316 stainless steel fluid head, without galling or seizing should inadvertent pressure surges cause contact. The close clearances combined with the rotor geometry, which gives a long sealing path between the pump inlet and outlet, means low slip operation. As a result, you achieve: high volumetric efficiency, good priming ability, metering capability and good flow control.

For High Viscosity Fluids, the large fluid cavities of the rotors ... plus the large, easy entry anti-cavitation ports ... allow efficient pumping of high viscosity fluids, slurries or even liquids with large chunks or particles.

For Non-Lubricating and Abrasive Fluids, the unique Waukesha Cherry-Burrell design has no bearings in the fluid being pumped, no sliding or rolling contact and no rotor-to-rotor contact. This produces MAXIMUM SERVICE LIFE even under severe operating conditions.

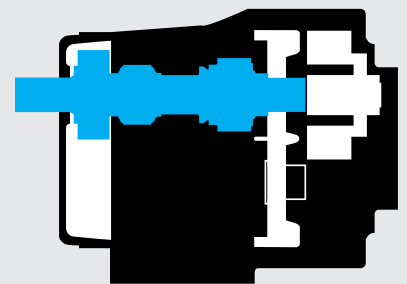
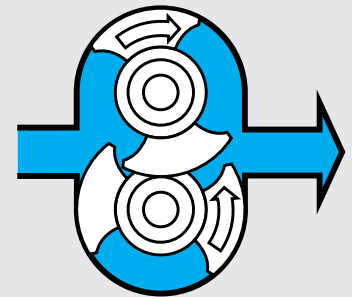
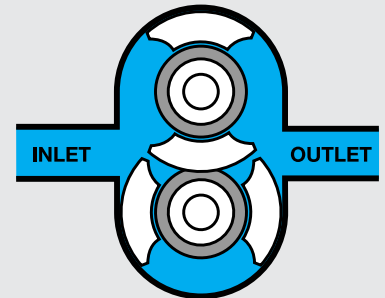
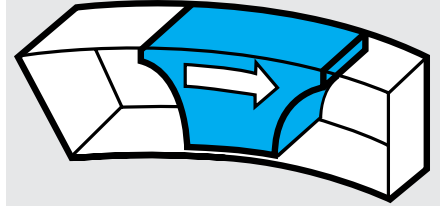

STANDARD & OPTIONS

Body

316 SS standard

- Optional:*
- Flush taps for future double seals.
 - Body retaining screws.

Ports

S Line standard

- Optional:*
- Bevel Seat, I-Line, Q-Line; European DIN, SMS or RJT.
 - Male NPT, 150 lb. & 300 lb. Flanges. (150 lb. standard on Model 320)
 - Rectangular Flange Inlet or Aseptic ports.
 - Extended ports.
 - Optional port sizes on 6, 18, 30 and 60 Models.

Covers

316 SS plain cover with 3-wing cover nuts standard.

- Optional:*
- Vent or drain connections.
 - Aseptic, jacketed or vented.
 - Hex cover nuts.

Rotors

Alloy 88 Twin Wing standard. Standard clearance for up to 200° F.

- Optional:*
- Hot clearance to 300° F. Clearance above 300° F. on application.
 - Special & front face clearances and slotted rotor hub for special applications.
 - Single wing for 30, 60, 130 and 220 models for minimal particulate damage.

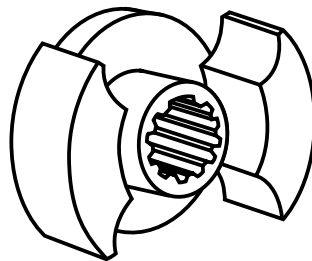

Twin Wing

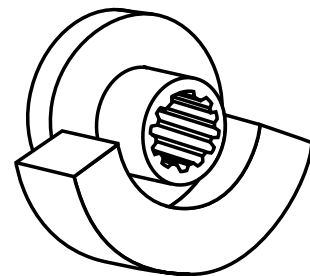

Single Wing

O-Rings

Buna-N Standard.

- Optional:* EPDM, Fluorocarbon (FKM), Silicone, Kalrez, PTFE Encapsulates

Seals

Single Buna-N O-Rings with Zirconia sleeve is standard.

- Options:*
- 316 SS sleeve.
 - Double O-Ring Seal with Flush Connection.
 - Single Mechanical Seal with Carbon (One Piece) vs. Ceramic Seal Faces.
 - Double Mechanical Seal with outer Carbon Seal Face & Flush Connections.
 - Chrome Oxide, Silicon Carbide, & Tungsten Carbide Seal Faces.
 - Two piece carbon inner seal.

Universal I Series

Cast iron, blue epoxy paint, 316 SS shafts, top shaft position is Standard.

- Options:
- Stainless Steel gearcase.
 - Steel-It paint.
 - 17-4 PH shafts.
 - Lower shaft position.
 - Bearing Isolators.
 - Stainless Steel bearing retainers.
 - Pedestal shims for side mounted pumps. **Left hand shaft position standard.**
 - Right hand shaft position on side mounted gearcase.

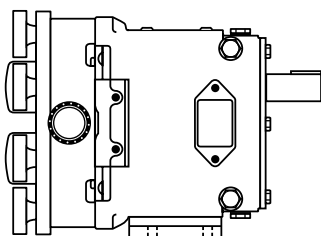

**Top Shaft Position
Standard**

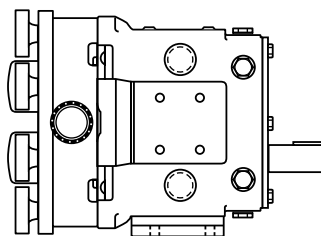

**Lower Shaft Position
Optional**

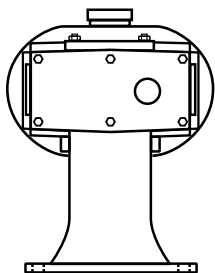

Standard left hand
shaft position
shown (right hand
optional)

Note: Pedestal foot is optional on Standard and Rectangular Flange models. Various standard heights are available and must be specified on order.

Optional Side Mount Gear Case for vertical fluid entry

Flat plate, epoxy painted, with adjustable feet, SS coupling guard, and Lovejoy or Woods coupling standard.

- Options:
- 304 SS unpolished plate base with adjustable feet.
 - Portable base with rubber wheels.
 - SS tubular bases.

WCB ISR Integral Speed Reducer Sizes 49, 79 and 239.

Direct connected gear motors.

Mechanical and Electronic Variable Speed Drives.

Hydraulic Motor Drives.

Gear cases

Bases

Drives

DIMENSIONS

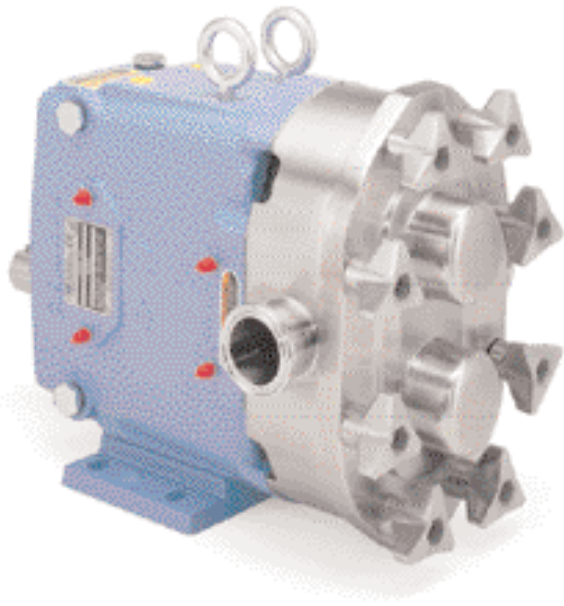
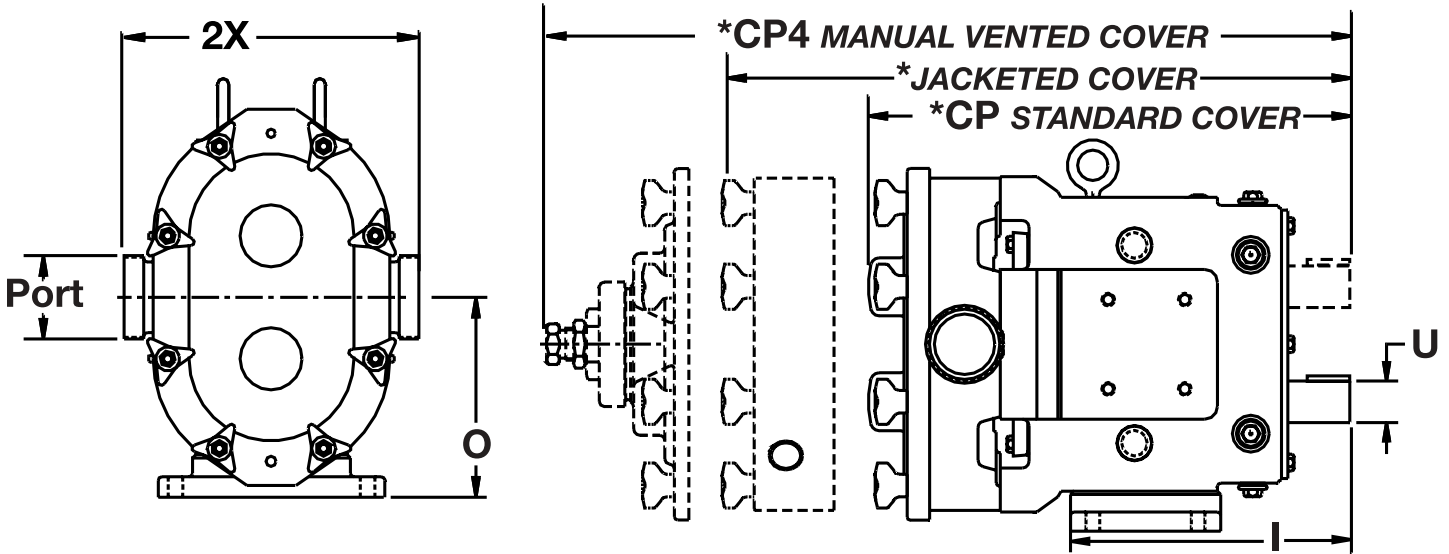

SIZE MODEL		CP	CP4	I	O	PORT SIZE	U +.000 -.001	2X	WT LBS/KG
006-U1	IN	12.04	15.25	7.66	4.21	1-1/2"	.875	6.97	52
	MM	306	387	194	107	-	22.23	177	24
015-U1	IN	12.04	15.25	7.66	4.21	1-1/2"	.875	6.97	52
	MM	306	387	194	107	-	22.23	177	24
018-U1	IN	12.46	15.67	7.66	4.21	1-1/2"	.875	7.09	54
	MM	316	398	194	107	-	22.23	180	24
030-U1	IN	14.58	17.67	8.83	5.21	1-1/2"	1.250	8.50	100
	MM	370	449	224	132	-	31.75	216	45
060-U1	IN	18.91	22.07	10.99	7.31	2-1/2"	1.625	10.75	255
	MM	480	561	279	186	-	41.28	273	116
130-U1	IN	19.85	23.01	10.99	7.31	3"	1.625	10.75	260
	MM	504	584	279	186	-	41.28	273	118
220-U1	IN	23.37	27.87	14.80	9.38	4"	2.000	13.25	450
	MM	594	708	376	238	-	50.80	337	204
320-U1	IN	30.17	-	17.80	10.38	6" 150# FLG	2.375	16.00	795
	MM	766	-	452	264	-	60.45	406	361

NOTE: Dimension "2X" applies for Bevel Seat, "S"-Clamp, "Q"-Clamp, 151 and 141 fittings (Except 320U2).

*NOTE: CP4 is the maximum dimension for all vented and jacketed cover options.

Universal I Series Rectangular Flange

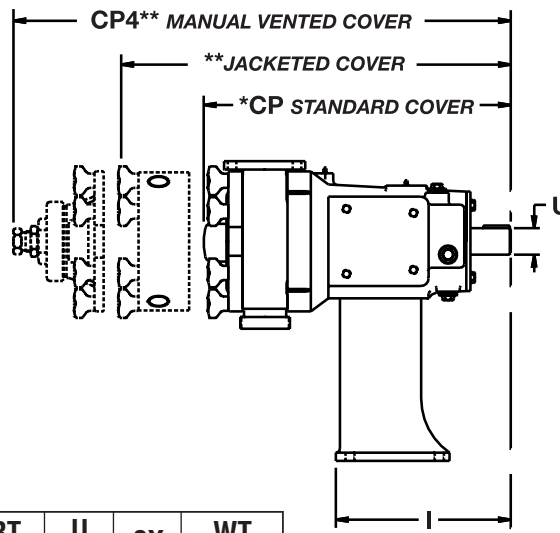
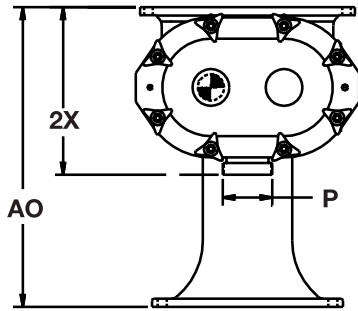

SIZE MODEL		AO*	CP	CP4	I	PORT SIZE	U +0.000 -0.001	2X	WT LBS/KG
014-U1	IN	12.50	12.04	15.25	7.66	1-1/2"	.875	7.11	47
	MM	318	306	387	195	-	22.23	181	21
024-U1	IN	12.50	12.46	15.67	7.66	1-1/2"	.875	7.11	49
	MM	318	316	398	195	-	22.23	181	22
034-U1	IN	14.25	14.58	17.67	8.49	2"	1.250	8.12	100
	MM	362	370	449	216	-	31.75	206	45
064-U1	IN	19.18	18.91	22.07	10.77	2-1/2"	1.625	10.31	255
	MM	487	480	561	274	-	41.28	262	116
134-U1	IN	19.18	19.85	23.01	10.77	3"	1.625	10.31	280
	MM	487	504	584	274	-	41.28	262	127
224-U1	IN	23.75	23.37	27.87	13.74	4"	2.000	12.87	505
	MM	603	594	708	349	-	50.80	327	229
324-U1	IN	36.00	30.17	-	16.86	6" 150 ^o FLG	2.375	17.88	775
	MM	914	766	-	428	-	60.33	454	352

*NOTE: Dimension AO is with tallest pedestal. Optional heights are available.

**NOTE: CP4 is the maximum dimension for all vented and jacketed cover options.

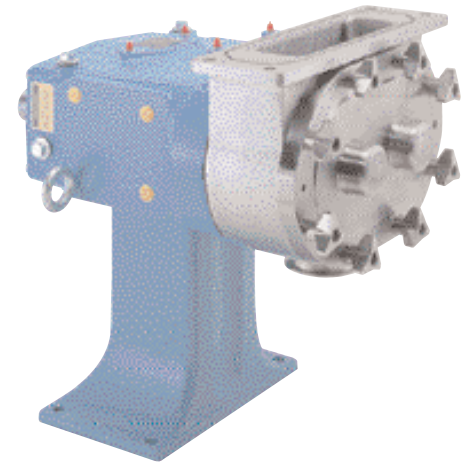

Universal I Series Aseptic Models

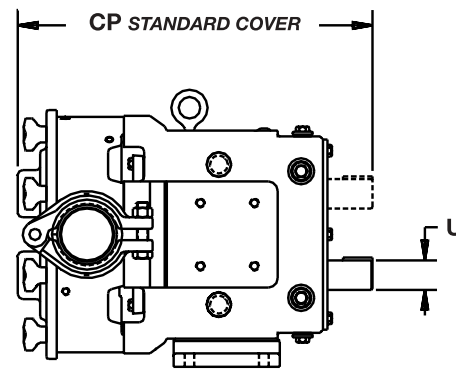
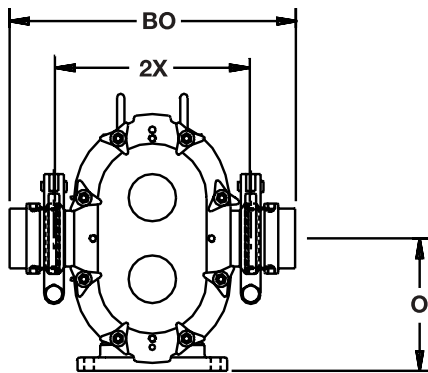

SIZE MODEL		BO	CP	O	PORT SIZE	U +0.000 -0.001	2X	WT LBS/KG
033-U1	IN	11.13	14.58	5.21	1-1/2" Sanitary Butt-Weld	1.250	8.63	105
	MM	283	370	132	-	31.75	219	48
133-U1	IN	15.77	19.59	7.31	3" Sanitary Butt-Weld	1.625	10.62	265
	MM	401	498	186	-	41.28	270	120
223-U1	IN	17.94	23.37	9.38	4" Sanitary Butt-Weld	2.000	13.13	455
	MM	456	594	238	-	50.80	334	206
323-U1	IN	-	30.17	10.38	6" 150 ^o FLG	2.375	16.00	795
	MM	-	766	264	-	60.45	406	361

When it is time to repair ...

***Waukesha Cherry-Burrell offers the following options
– you pick the one that meets your needs.***

Factory Remanufacturing Program – WCB traditional program

- No need to return your pump until you receive your new remanufactured pump, since we have a large supply of exchange pumps.
- Substantial savings over new pump.
- New pump performance and warranty.
- New pumps eligible for Remanufacturing Program twice.
- See Bulletin FH-1728 for more details.

Factory Inspect and Advise Program

- Return your pump for complete factory inspection.
- Cost effective options to match your performance/budget needs.
- Your body may be remachined up to 6 times.
- Replacement rotors and parts available with no need to return pump again.
- Factory warranty.
- See Bulletin FH-1728 for more details.

WCB Certified Pump Repair Centers

- Local distributors with factory trained and certified service technicians.
- Quick local response.
- Genuine WCB parts.
- Flexible repair programs to meet your needs.
- Local warranty.

Waukesha Cherry-Burrell Warranty

Seller warrants its products to be free from defects in materials and workmanship for a period of one (1) year from the date of shipment. This warranty shall not apply to products which require repair or replacement due to normal wear and tear or to products which are subjected to accident, misuse or improper maintenance. This warranty extends only to the original buyer. Products manufactured by others but furnished by seller are exempted from this warranty and are limited to the original manufacturer's warranty.

SPX Process Equipment



SPX Process Equipment

611 Sugar Creek Road

Delavan, WI 53115 USA

Tel: 1-800-252-5200 or 262-728-1900

Fax: 1-800-252-5012 or 262-728-4904

E-mail: custserv@gowcb.com

Web site: www.spxprocessequipment.com



FH-1701
WCB-5K-503CG
Printed in U.S.A.

Effective 03/01