

Waukesha Cherry-Burrell

W30 High Pressure/ High Temperature Sample Valve

- 316L Stainless Steel Construction Machined from Solid Bar Stock with All Surfaces Machined 32RA or Better
- Product Line or Vessel Connection 3/4-Inch Weld, 1/2-Inch "S" Clamp, 1-1/2-Inch "S" Clamp
- SIP – Steam or Water Flush Connection 1/8-Inch Stainless Steel Tube
- Large Knurled Nylon Handle with Waukesha 88 (Non-Gauling Alloy) Metal Liner
- Stem Travel Limited for Increased Safety
- Quick Disassembly for Inspection or Cleaning by Removal of 3/4-Inch Body "S" Clamp
- Product Discharge
1/4-Inch Hose Barb or 3/8-Inch Hose Barb
- Teflon Seal with Special Pressure Reducing Orifice Prior to Seal
- Viton O-Ring and Body Gasket

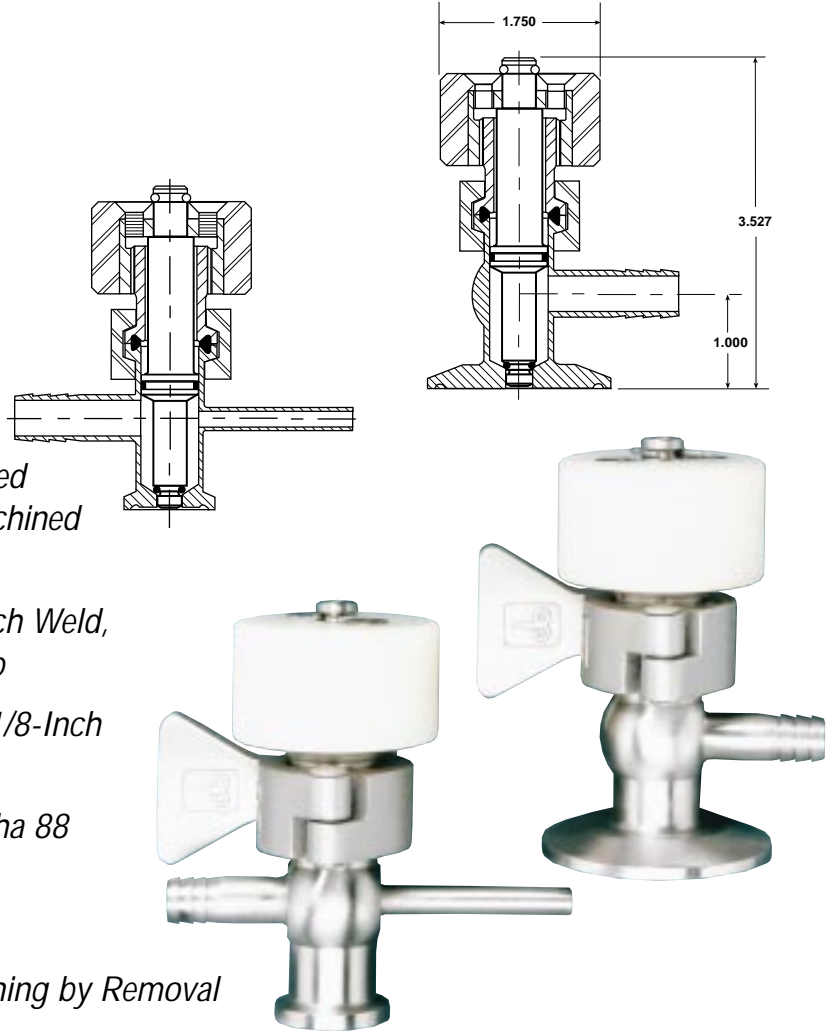

Waukesha Cherry-Burrell
611 Sugar Creek Road
Delavan, WI 53115 USA
Tel: 1-800-252-5200 or 414-728-1900
Fax: 1-800-252-5012 or 414-728-4904
E-mail: custserv@waukesha-cb.com
Web site: <http://www.waukesha-cb.com>



ISO 9001
CERTIFIED



FH-1860A
TA-2M-498JA
Printed in U.S.A.
Effective 6/97