

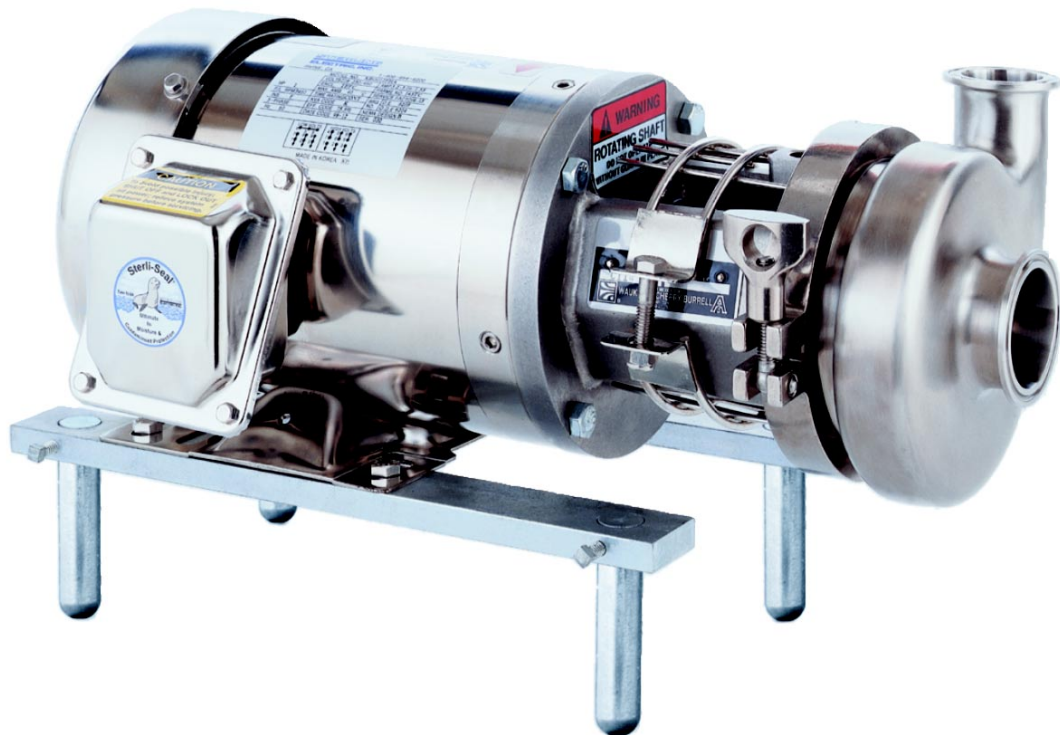

**Waukesha
Cherry-Burrell**
A Unit of SPX Process Equipment

Operation and Maintenance Manual C-Series Centrifugal Pumps



**Read and understand this manual
prior to installing, operating or servicing this equipment**



611 Sugar Creek Road
Delavan, WI 53115 USA

Tel: 1.800.252.5200 (within the USA) • (262)728.1900
Fax: 1.800.252.5012 (within the USA) • (262)728.4904

E-mail: custserv@gowcb.com
Web site: www.gowcb.com

Information contained in this manual is subject to change without notice and does not represent a commitment on the part of Waukesha Cherry-Burrell. No part of this manual may be reproduced or transmitted in any form or by any means, electronic or mechanical, including photocopying and recording, for any purpose, without the express written permission of Waukesha Cherry-Burrell.

Waukesha Cherry-Burrell All Rights Reserved

Issued: **November 26, 2001**
Revised: **April 1, 2003**

Publication: **95-03008**

Table of Contents

Waukesha Cherry-Burrell Warranty	6
Shipping Damage or Loss	6
Warranty Claim	6
Safety	7
Care of Stainless Steel	8
Stainless Steel Corrosion	8
Cleaning Stainless Steel	9
Suggested Cleaning Regimen	9
Suggested Passivation Regimen	9
Introduction.....	10
Description	10
Operating Parameters	12
Capacity	12
Viscosity:	12
Maximum operating temperature	12
Operating Speeds	12
Standard Features	12
Installation.....	16
Pump Location	16
Pump Leveling	16
Supply And Discharge Piping/Valves	16
Installations That May Cause Operation Problems	18
Electrical Connections	19
Flush Seal Option	19
Before First Startup	19
Clean Pump And Piping	19
Cleaning Safety Procedures	20
Manual Cleaning	20
Cleaning-In-Place (CIP)	20
Preliminary Test Run	20
Check For Possible Motor Overload Condition	20
<i>Ammeter Test</i>	20
Operation.....	21
Starting the Pump	21
Priming the Pump	21
<i>Priming The Pump With The Feed Source Above Pump Level</i>	21
<i>Priming The Pump With The Feed Source Below Pump Level</i>	22
Stopping The Pump	22
Maintenance	23
Scheduled Maintenance	23
Routine Maintenance	23
Pump Disassembly	23
Replacing Motor	25
Installing the Adaptor	26
Stub Shaft Adjustment	26
Stub Shaft Adjustment (Models C-114 through C-328)	27
Seal Repair	28
Type E Water Cooled Balanced Double Seal	28
<i>Seal Servicing</i>	29
<i>Installing E Seal</i>	29

Table of Contents

Parts Lists	32
C-100	32
C-114	34
C-216	36
C-218	38
C-328	40
Type "E" Water Cooled Double Balanced Seal Option	42
Type "DG" Seat Assembly Option	44
Troubleshooting	46

Waukesha Cherry-Burrell Warranty

Seller warrants its products to be free from defect in materials and workmanship for a period of one (1) year from the date of shipment. This warranty shall not apply to products which require repair or replacement due to normal wear and tear or to products which are subjected to accident, misuse or improper maintenance. This warranty extends only to the original Buyer. Products manufactured by others but furnished by Seller are exempted from this warranty and are limited to the original manufacturer's warranty.

Seller's sole obligation under this warranty shall be to repair or replace any products that Seller determines, in its discretion, to be defective. Seller reserves the right either to inspect the products in the field or to request their prepaid return to Seller. Seller shall not be responsible for any transportation charges, duty, taxes, freight, labor or other costs. The cost of removing and/or installing products which have been repaired or replaced shall be at Buyer's expense.

Seller expressly disclaims all other warranties, express or implied, including without limitation any warranty of merchantability of fitness for a particular purpose. The foregoing sets forth Seller's entire and exclusive liability, and Buyer's exclusive and sole remedy, for any claim of damages in connection with the sale of products. In no event shall Seller be liable for any special consequential incidental or indirect damages (including without limitation attorney's fees and expenses), nor shall Seller be liable for any loss of profit or material arising out of or relating to the sale or operation of the products based on contract, tort (including negligence), strict liability or otherwise.

Shipping Damage or Loss

If equipment is damaged or lost in transit, file a claim at once with the delivering carrier. The carrier has signed the Bill of Lading acknowledging that the shipment has been received from WCB in good condition. WCB is not responsible for the collection of claims or replacement of materials due to transit shortages or damages.

Warranty Claim

Warranty claims must have a **Returned Goods Authorization (RGA)** from the Seller before returns will be accepted.

Claims for shortages or other errors, exclusive of transit shortages or damages, must be made in writing to Seller within ten (10) days after delivery. Failure to give such notice shall constitute acceptance and waiver of all such claims by Buyer.

Safety

READ AND UNDERSTAND THIS MANUAL PRIOR TO INSTALLING, OPERATING OR SERVICING THIS EQUIPMENT

Waukesha Cherry-Burrell recommends users of our equipment and designs follow the latest Industrial Safety Standards. At a minimum, these should include the industrial safety requirements established by:

1. Occupational Safety and Health Administration (OSHA), Title 29 of the CFR
Section 1910.212- General Requirements for all Machines
2. National Fire Protection Association, ANSI/NFPA 79
ANSI/NFPA 79- Electrical Standards for Industrial Machinery
3. National Electrical Code, ANSI/NFPA 70
ANSI/NFPA 70- National Electrical Code
ANSI/NFPA 70E- Electrical Safety Requirement for Employee Workplaces
4. American National Standards Institute, Section B11

Attention: Servicing energized industrial equipment can be hazardous. Severe injury or death can result from electrical shock, burn, or unintended actuation of controlled equipment. Recommended practice is to disconnect and lockout industrial equipment from power sources, and release stored energy, if present. Refer to the National Fire Protection Association Standard No. NFPA70E, Part II and (as applicable) OSHA rules for Control of Hazardous Energy Sources (Lockout-Tagout) and OSHA Electrical Safety Related Work Practices, including procedural requirements for:

- Lockout-tagout
- Personnel qualifications and training requirements
- When it is not feasible to de-energize and lockout-tagout electrical circuits and equipment before working on or near exposed circuit parts

Locking and Interlocking Devices: These devices should be checked for proper working condition and capability of performing their intended functions. Make replacements only with the original manufacturer's renewal parts or kits. Adjust or repair in accordance with the manufacturer's instructions.

Periodic Inspection: Industrial equipment should be inspected periodically. Inspection intervals should be based on environmental and operating conditions and adjusted as indicated by experience. At a minimum, an initial inspection within 3 to 4 months after installation is recommended. Inspection of the electrical control systems should meet the recommendations as specified in the National Electrical Manufacturers Association (NEMA) Standard No. ICS 1.3, Preventative Maintenance of Industrial Control and Systems Equipment, for the general guidelines for setting-up a periodic maintenance program.

Replacement Equipment: Use only replacement parts and devices recommended by the manufacturer to maintain the integrity of the equipment. Make sure the parts are properly matched to the equipment series, model, serial number, and revision level of the equipment.

Warnings and cautions are provided in this manual to help avoid serious injury and/or possible damage to equipment:



DANGER: marked with a stop sign.
Immediate hazards which **WILL** result in severe personal injury or death.



WARNING: marked with a warning triangle.
Hazards or unsafe practices which **COULD** result in severe personal injury or death.



CAUTION: marked with a warning triangle.
Hazards or unsafe practices which **COULD** result in minor personal injury or product or property damage.

Care of Stainless Steel

Stainless Steel Corrosion

The austenitic stainless steel components in Waukesha Cherry-Burrell equipment are machined, welded and assembled by skilled craftsmen using manufacturing methods to preserve the corrosion resistant quality of the stainless steel.



CAUTION: *Highly corrosive acids, such as hydrofluoric, hydrochloric and sulfuric, are not recommended as acidic cleaners for austenitic stainless steel. Phosphoric and citric acid-based cleaners at low concentrations (0.5 - 1.5% w/w) and temperature (phosphoric < 115° F (45° C) and citric < 160° F (70° C)) can be used in specific applications, as recommended by reputable chemical manufacturers. Acidic cleaners should contain corrosion inhibitors to reduce the corrosive effects on the metal.*

Corrosion resistance of austenitic stainless steel is greatest when a layer of oxidation is formed on the surface of the metal. If the protective surface is disturbed or destroyed, the metal easily can be corroded by contact fluids.

1. Regularly inspect austenitic stainless steel equipment for surface deposition and/or localized **pitting corrosion**. If deposition or discoloration is detected, disassemble equipment, remove components and soak in a mild alkaline-based detergent. Rinse using warm water. Allow equipment to air dry thoroughly before assembly.
2. Regularly check all electrical devices and verify all equipment is grounded to avoid any **electrolytic-concentration corrosion**.
3. Regularly inspect joints and gaskets in the system for **crevice corrosion**.
4. Regularly inspect equipment for trapped air pockets to avoid pitting caused by **oxygen-concentration corrosion**.
5. Regularly inspect any areas of equipment using dissimilar metals connected by a mechanical joint to avoid **galvanic corrosion**.
6. Regularly inspect system components not manufactured with stabilized low carbon stainless steel (**intergranular corrosion**).
7. Regularly inspect equipment for implied stresses from either mechanical or chemical environments to avoid **stress corrosion cracking**. Chloride stress corrosion cracking of austenitic stainless steel is caused by the presence of chlorides on the surface of the metal, inducing cracks and fatiguing the metal. The use of chemicals or fluids containing chlorides should be avoided.

Cleaning Stainless Steel

Cleaning of austenitic stainless steel (AISI 300 Series), manually or chemically, is dependant on the process environment the equipment is operated in. Typically, the cleaning regimen should be developed and reviewed by a plant sanitarian or a formulation representative of a reputable chemical supply company. The following chemicals may be utilized to clean, passivate and disinfect equipment prior to operation.

- **Alkaline Detergent:** A blended alkaline detergent may be used to clean equipment. The detergent should be a blended sodium hydroxide/water detergent, designed for use with austenitic stainless steel equipment and used at initial concentrations of 1-3% w/w solution at a temperature of 160° F (70° C) to 195° F (90° C) (dependant on the chemical supplier). The detergent should be formulated with a metal chelation agent, such as sodium gluconate or gluconic acid, to remove metal ions in the water (hardness dependant) and a surfactant to increase the rinse ability of the solution.
- **Acid:** To neutralize any residual alkali and render a passive surface on the stainless steel, a 160° F (70° C) solution of citric acid and water at a concentration of 0.5-3% w/w can be used. Phosphoric acid may be used at concentrations of 0.5-1.5% w/w at 115° F (45° C). If phosphoric acid is used, corrosion inhibitors should be blended in prior to use.
- **Disinfectant (Food Plants):** Caution should be used with application of chemical disinfectants. Most chemical disinfectants are halogen- or quarternary ammonium-based compounds and, in high concentrations, are very corrosive to austenitic stainless steel. Typically, the most common disinfectant, iodophor, can be used with a maximum concentration of 25 mg/l at a maximum temperature of < 80° F (25° C). Other common disinfectants, such as sodium hypochlorite and chloroamine, are not recommended.

Suggested Cleaning Regimen

1. Cold water prerinse 60° F - 80° F (15° C - 25° C)
2. Warm water prerinse 115° F - 140° F (45° C - 60° C)
3. Alkali recirculation 160° F - 195° F (70° C - 90° C)
4. Warm water postrinse 115° F - 140° F (45° C - 60° C)
5. Acid recirculation 80° F - 115° F (25° C - 45° C)
6. Warm water postrinse 115° F - 140° F (45° C - 60° C)

Suggested Passivation Regimen

1. Cold water prerinse 60° F - 80° F (15° C - 25° C)
2. Warm water prerinse 115° F - 140° F (45° C - 60° C)
3. Citric acid recirculation 140° F - 160° F (60° C - 70° C)
4. Warm water postrinse 115° F - 140° F (45° C - 60° C)
5. Cold water postrinse 60° F - 80° F (15° C - 25° C)

For manual cleaning, use only soft, non-metallic brushes, sponges or pads. Brush with the grain on polished surfaces. Avoid scratching.

Introduction

Description

This manual contains installation, operation, cleaning, repair instructions and parts lists for the "C" Series Centrifugal Pumps. It also provides a troubleshooting chart to help in determining and correcting possible pump problems.

The "C" Series Centrifugal Pumps consist of two sections, the motor assembly and the pump components. (See Figure 1). The pump is mounted on the drive motor with an adaptor, and is coupled to the motor with a stainless steel stub shaft. The pump impeller mounts on

the stub shaft and is secured with a floating impeller retainer pin.

The casing is joined to the adaptor by a clamp, this is to simplify removal. This design style also permits the casing outlet to be rotated to various positions. (The C-100 is secured with two wing nuts and may only be mounted with the outlet facing straight up.) The Type "D" seal assures a long wear life. The Type "D" seal is a standard mechanical external balanced seal. The drive motor is mounted on a frame with adjustable legs in accordance with sanitary design requirements. This configuration also provides for simple installation and easy leveling of the pump.

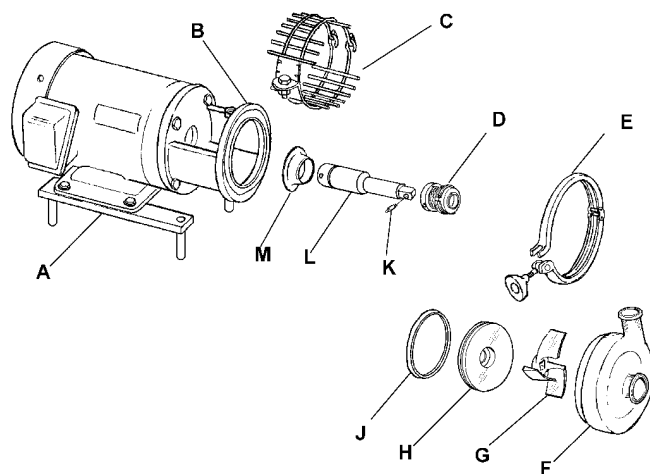
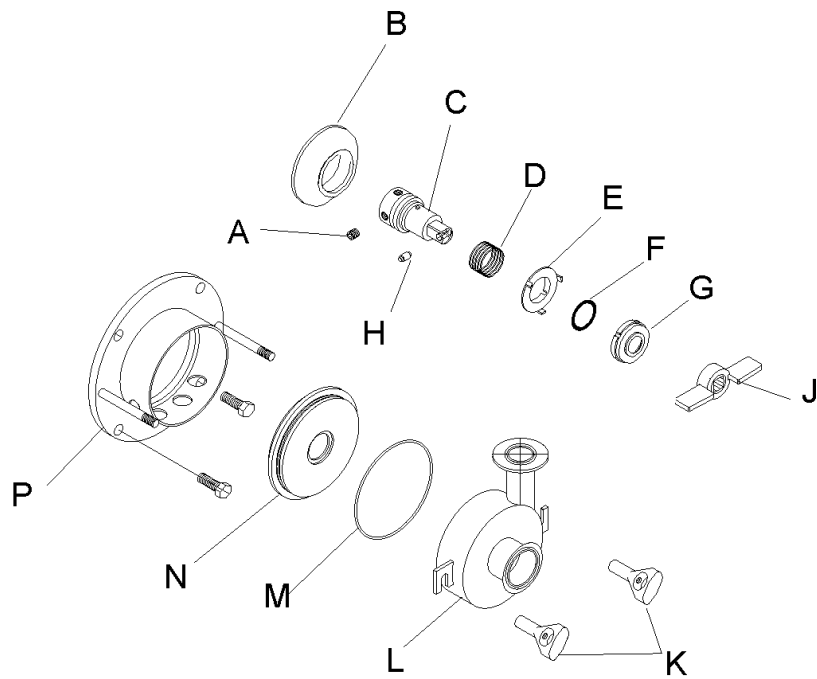

Figure 1 - Pump Components for C-114 Through C-328

Table 1: Callouts for Figure 1

A. Motor Leg Kit Assembly	G. Impeller
B. Adaptor	H. Backplate
C. Guard	J. Backplate Gasket
D. Type "D" Seal Assembly	K. Impeller Retainer
E. Clamp	L. Stub Shaft
F. Casing	M. Deflector



CT100-014

Figure 2 - Pump Components for C-100

Table 2: Callouts for Figure 2

A. Shaft Set Screw	H. Impeller Retainer
B. Deflector	J. Impeller
C. Stub Shaft	K. Wing Nut
D. Spring	L. Casing
E. Cup	M. Backplate Gasket
F. O-ring	N. Backplate
G. Seat Seal	P. Adaptor

Operating Parameters

Capacity

0 To 780 GPM

Viscosity:

0 To 1500 CPS

Maximum operating temperature

212°F.(100° C.)

Operating Speeds

1 to 2100 RPM - 50HZ

1 to 3500 RPM - 60HZ

Standard Features

- Casing, backplate and impeller are 316 stainless steel with polished sanitary finish.
- Port Connection: S-Line clamp fittings are standard.
- Power: Supplied by a standard foot-mounted C-face motor, through 60 Horsepower.
- Seal: "Type D." Seal material is carbon rotating on stationary stainless steel backplate. Water cascading attachment is available option (Part Number 60112). See page 36.
- Seal: Type "DG" (Gland ring with replaceable seal seat) used with "Type D" seal. See page 44.
- Seal: "Type E" Water cooled balanced double seal (carbon). See page 42.
- Sanitary Polish: 150 Grit (32 RA) Finish
- Fluoroelastomer O-rings

Table 3: Mechanical Specifications

MODEL	PORT SIZE Inches		IMPELLER DIA. Inches (mm)	
	Inlet	Discharge	Minimum	Maximum
C-100	1-1/2	1	3.0 (76)	3.68 (93)
	-	-		
C-114	1-1/2	1-1/2	2.5 (63)	4.0 (101)
	2	1-1/2		
C-216	2	1-1/2	4.0 (101)	6.0 (152)
	2-1/2	1-1/2		
C-218	2	1-1/2	6.0 (152)	8.0 (203)
	3	1-1/2		
C-328	3	2	5.5 (139)	8.0 (203)
	4	2		

Table 4: Available Motor Frame Sizes

Model	Size
C-100	56C 140TC
C-114	140TC 180TC
C-216	56C-140TC 180TC 210TC 250TC
C-218	140TC 180TC 210TC 250TC 280TC
C-238	180TC 210TC 250TC 280TC 320TC

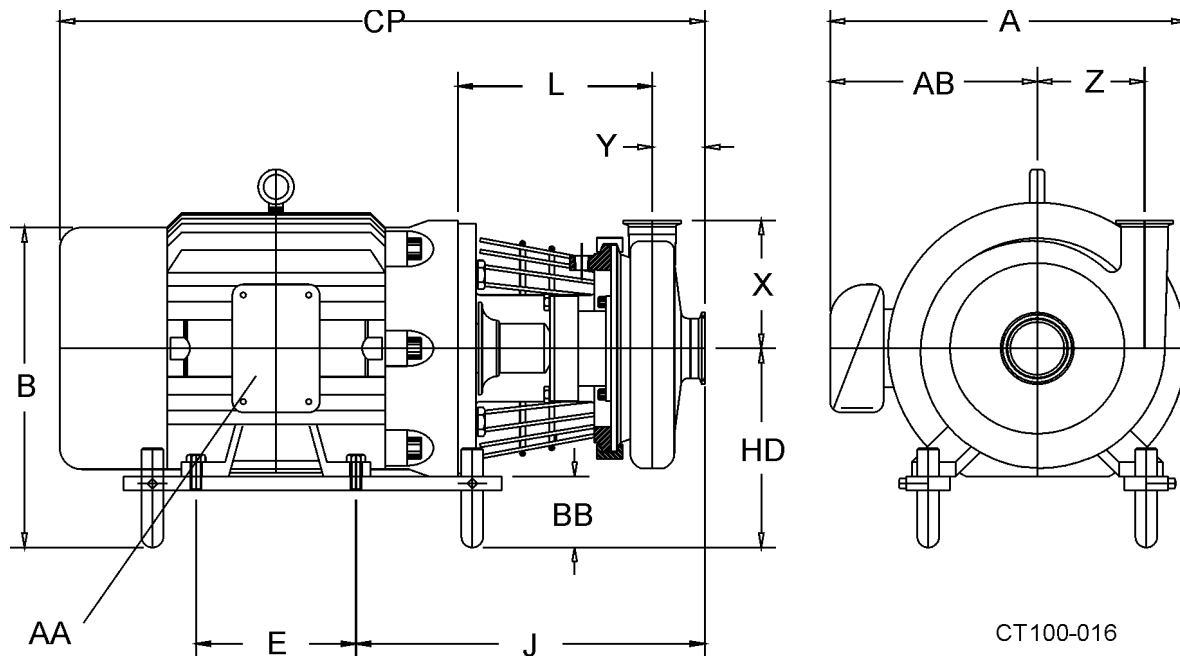

Figure 3 - Pump Dimensions

AA= Conduit Size BB = 2-1/2" +/- 1"

Table 5: Callouts for Figure 3

MODEL FRAME		A	B	CP	J	E	L	HD	AA	AB
C100	56C	6-1/2 (165 mm)	9-7/32 (241 mm)	17-5/8 (447 mm)	6-7/8 (174 mm)	3 (76 mm)	2-3/4 (70mm)	5-1/2 (139 mm)	1/2 (12 mm)	3-1/4 (82 mm)
	143TC	9-11/16 (246 mm)	9-1/2 (241 mm)	19-31/32 (507 mm)	7- 11/16 (195 mm)	4 (101 mm)	3-3/4 (95 mm)	6 (152 mm)	3/4 (19 mm)	6-15/16 (176 mm)
C114	56C	6-1/2 (165 mm)	9-7/32 (241 mm)	16-11/16 (415 mm)	10-3/8 (263 mm)	3 (76 mm)	6-7/32 (158 mm)	5-1/2 (139 mm)	1/2 (12 mm)	3-1/4 (82 mm)
	140TC	9-11/16 (246 mm)	9-1/2 (241 mm)	19-1/4 (488 mm)	10-11/16 (271 mm)	5 (127 mm)	6-7/32 (158 mm)	6 (152 mm)	3/4 (19 mm)	6-15/16 (176 mm)
	182TC	11-5/8 (295 mm)	11-7/16 (290 mm)	22-1/4 (565 mm)	12 (340 mm)	5-1/2 (139 mm)	6-25/32 (172 mm)	6-31/32 (177 mm)	3/4 (19 mm)	7-7/8 (200 mm)
C216	140TC	9-11/16 (246 mm)	9-1/2 (241 mm)	19-1/4 (488 mm)	10-27/32 (275 mm)	5 (127 mm)	6-1/16 (154 mm)	6 (152 mm)	3/4 (19 mm)	6-15/16 (176 mm)
	180TC	11-5/8 (295 mm)	11-7/16 (290 mm)	22-1/4 (565 mm)	12-7/32 (310 mm)	5-1/2 (139 mm)	6-11/16 (170 mm)	6-31/32 (177 mm)	3/4 (19 mm)	7-7/8 (200 mm)
	210TC	13-1/8 (333 mm)	12-15/16 (328 mm)	25-13/16 (655 mm)	13-31/32 (354 mm)	6 (152 mm)	7-13/16 (198 mm)	7-23/32 (196 mm)	3/4 (19 mm)	8-7/8 (225 mm)
	250TC	14-1/2 (368 mm)	15-1/32 (381 mm)	31-1/16 (788 mm)	14-1/2 (368 mm)	10 (254 mm)	8-1/2 (216 mm)	8-3/4 (222 mm)	1 (25 mm)	9-1/2 (241 mm)
C218 C328	140TC	9-11/16 (246 mm)	9-1/2 (241 mm)	19-1/4 (488 mm)	11 (279 mm)	5 (127 mm)	6-5/16 (160 mm)	6 (152 mm)	3/4 (19 mm)	6-15/16 (176 mm)
	180TC	11-5/8 (295 mm)	11-7/16 (290 mm)	22-1/4 (565 mm)	12-9/32 (312 mm)	5 (127 mm)	6-15/16 (176 mm)	6-31/32 (177 mm)	3/4 (19 mm)	7-7/8 (200 mm)
	210TC	13-1/8 (333 mm)	12-15/16 (328 mm)	25-13/16 (655 mm)	13-9/32 (337 mm)	6 (152 mm)	7-5/16 (185 mm)	7-23/32 (196 mm)	3/4 (19 mm)	8-7/8 (225 mm)
	250TC	14-1/2 (368 mm)	15-1/32 (381 mm)	31-1/16 (788 mm)	14-21/32 (372 mm)	10 (254 mm)	8-3/16 (208 mm)	8-3/4 (222 mm)	1 (25 mm)	9-1/2 (241 mm)
	280TC	20-5/8 (524 mm)	17-9/32 (439 mm)	32-1/4 (819 mm)	15-9/32 (388 mm)	11 (279 mm)	8-13/16 (224 mm)	9-1/2 (241 mm)	2 (50 mm)	13-1/8 (333 mm)
	320TC	23-1/8 (587 mm)	21 (533 mm)	35-7/16 (900 mm)	17-5/32 (435 mm)	12 (304 mm)	9-11/16 (246 mm)	10-1/2 (266 mm)	2 (50 mm)	14-1/8 (358 mm)

NOTE: Dimensions are guidance only. Contact your WCB Representative for more detailed measurements if needed

Table 6: Callouts for Figure 3

Model	Suction	Discharge	X	Y	Z
C100	1-1/2	1	3-1/2 (88 mm)	1 1/2 (38 mm)	1-29/64 (37 mm)
C114	1-1/2 OR 2	1-1/2	3-5/8 (92 mm)	1-5/8 (41 mm)	2-5/8 (66 mm)
C216	2 OR 2-1/2	1-1/2	4-1/2 (144 mm)	1-15/16 (49 mm)	3-11/16 (93 mm)
C218	2 OR 3	1-1/2	5-1/2 (139 mm)	1-15/16 (49 mm)	4-3/4 (120 mm)
C328	3 OR 4	2	5-1/2 (139 mm)	2-1/4 (57 mm)	4-3/4 (120 mm)

Installation

Unpack all parts of your equipment and inspect for damages that may have occurred during shipping. Report any damage to the carrier.

All ports are covered at the factory to keep out foreign objects during transit. If the covers are missing or damaged, a thorough inspection of fluid head, by removing the pump cover, is recommended. Be sure pumping head is clean and free of foreign material before rotating shaft.

Pump Location

1. Locate pump as near as practical to the liquid supply.
2. Keep supply piping short and straight to keep pump supplied with liquid and prevent damaging cavitation.
3. Pump should be accessible for service and inspection during operation.
4. Motor must be protected from flooding.

Pump Leveling

Level the pump by loosening the set screws (See Figure 4 item A) to adjust the length of the legs.

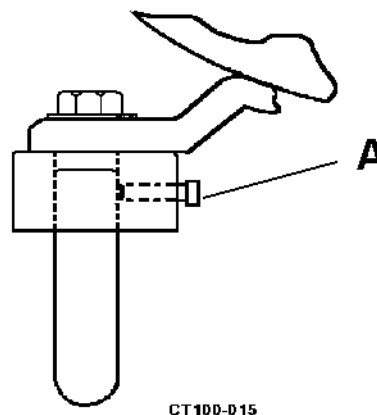

Figure 4 Leveling Leg Set Screw Location

Supply And Discharge Piping/ Valves

- Use line size equal to, or larger than, connection size on pump, especially the inlet supply line.
- Keep supply line as short and straight as possible and use as few elbows as possible, valves or other types of restriction. Avoid up and down rises that will trap air.
- Be certain all joints in suction line are well sealed to prevent air leaks.

- Maintain a straight length of pipe (See Figure 5 item A) at least 8 diameters long at the pump inlet.

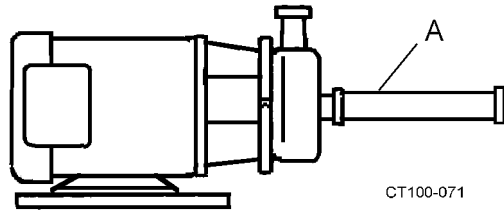

Figure 5 - Straight Pipe Length

- The pump casing may be rotated with the discharge connection pointing in any direction; best pump performance will be with the outlet up, to the left or positions in between; these positions insure a flooded casing and prevent problems due to air in the system. See Figure 5.

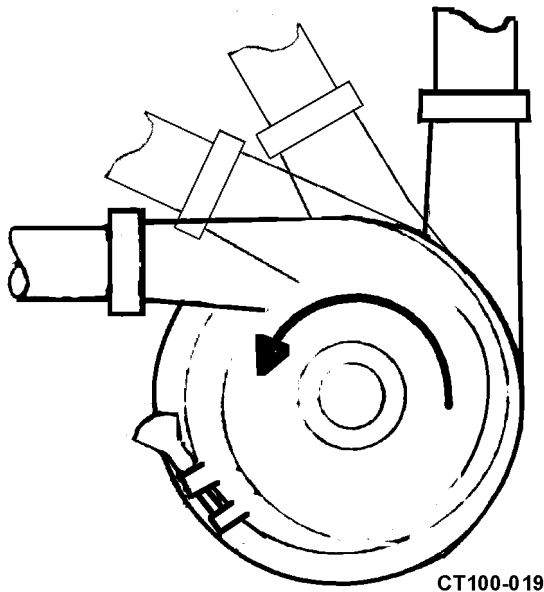

Figure 6 - Recommended Discharge Positions

- All joints in suction line must be well sealed to prevent air from being sucked into the system.

- Support supply and discharge piping near the pump so that no strain is put onto pump casing.

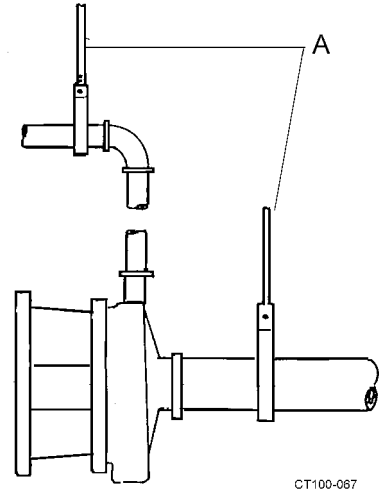

Figure 7 - Pipe Supports

- If an expansion joint is used, install a pipe anchor between it and the pump.
- If a reducer is connected to inlet, use eccentric type to prevent problems due to trapped air. See Figure 8.

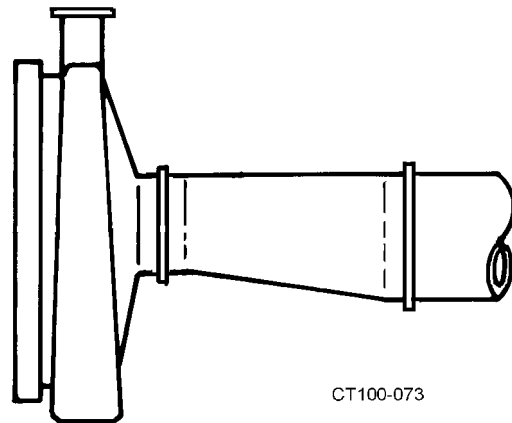

Figure 8 - Correct Eccentric Installation

CAUTION

The pump and piping may contain sharp edges. Wear gloves to help avoid injuries from these hazards.

- Line slope will depend on application requirements; best pump operation is with supply line sloped slightly upward toward pump to prevent trapped air. If system must drain into pump casing, keep downward slope to a minimum or priming problems may occur.
- Install shutoff valves to isolate pump from supply and discharge lines to allow pump service without draining system.
- This pump is not self priming. If pump is installed above supply liquid level, install foot valve or other system check valve to keep system flooded for priming. (See Figure 9 item B).
- A throttling valve may be required to control pump flow rate to prevent motor overload. Always install throttling valve (See Figure 9 item A) in discharge piping and at least 10 diameters from pump outlet.

Never install throttling valve in supply piping. See Figure 9.

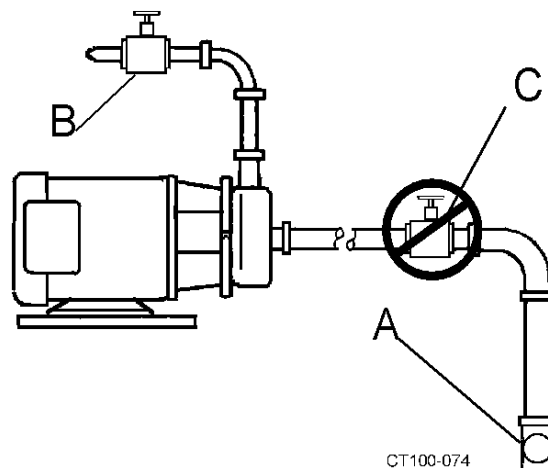

Figure 9 - Valve Piping Installation

Installations That May Cause Operation Problems

- Any system throttling valves or similar devices to control flow rate must be installed in the discharge line. **Do not** install any system throttling valves or similar devices to control flow rate in the supply line. Restriction in the supply line may cause cavitation and pump damage.
- "Water hammer" in the system can damage the pump and other system components. Water hammer often occurs when valves in the system are suddenly closed causing lines to move violently and with a loud noise. When this condition is present, find and eliminate the source of the water hammer. One way to eliminate water hammer is to slow down the actuation speed of the valve.
- Do not expose pump to freezing temperatures with liquid in casing. Frozen liquid in casing will damage pump. Drain casing before exposing to freezing temperatures.

Electrical Connections

WARNING

To avoid electrocution, ALL electrical installation should be done by a registered Electrician, following Industry Safety Standards. All power must be OFF and LOCKED OUT during installation.

- Read motor manufacturer's instructions before making installation. Follow manufacturer's lubrication schedules.
- Check motor nameplate to be sure motor is compatible with electrical supply and all wiring, switches, starters. Make sure all overload protections are correctly sized.

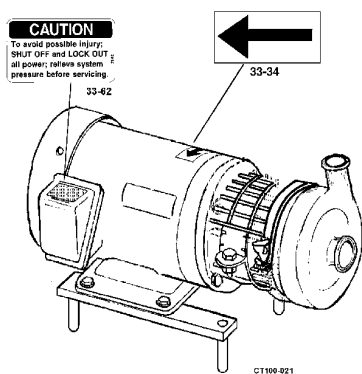

Figure 10 - Replaceable Label Location

- Check pump rotation following electrical installation. Correct rotation is counterclockwise when facing pump inlet connection. See Figure 6.

Flush Seal Option

When this option is ordered, a fitting assembly (Part Number 60112) (See Figure 11 item B) is

supplied for directing a flow of water onto the backplate/seal area.

- The water cascade block (See Figure 11 item A) must be above the seal on the assembled backplate to flow water onto the seal face.
- The connection is 1/4 inch O.D. tubing.
- Required flow is approximately 5 U.S. gallons per hour.
- The recommended water supply is - cool and filtered. If product solidifies at cool temperature, warm or hot water can be used

NOTE: To prevent hose contact with rotating shaft and seal parts during operation, pull excess hose to outside of seal guard.

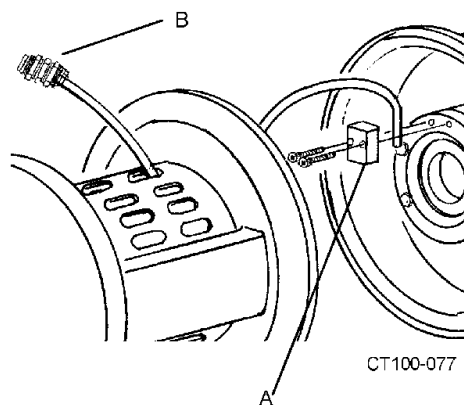

Figure 11 - Cascade System Installation

Before First Startup

Clean Pump And Piping

Disassemble pump and clean all product contact parts and seal parts prior to first operation. Follow instructions in the “Cleaning Safety Procedures” on page 20 and “Pump Disassembly” on page 23. The pump should be

thoroughly cleaned of any materials which could have accumulated during installation.

Cleaning Safety Procedures

Manual Cleaning

- Do not use toxic and/or flammable solvents.
- Lock out electrical power and shut off all air prior to cleaning equipment.
- Keep electrical panel covers closed and power off when washing equipment.

WARNING

To prevent an accidental start-up the power source should be locked out using your lock and key.

- Clean up spills as soon as possible.
- Never attempt cleaning equipment while it is operating.
- Wear proper protective clothing.

Cleaning-In-Place (CIP)

1. Make certain that all connections in cleaning circuit are properly applied and tight to avoid contact with hot water or cleaning solutions.
2. When cleaning cycle is controlled from remote or automated cleaning center, establish safe procedures to avoid automatic start-up while servicing equipment in the circuit.

Preliminary Test Run

The system should be tested using a preliminary run with the materials that will be

pumped. **DO NOT** run the pump at this time to produce final product.

See "Starting the Pump" on page 21.

Check For Possible Motor Overload Condition

Certain combinations will overload motor when operated with open unrestricted discharge which results in too high flow rate. Additional discharge restriction may be required to lower flow rate and lower horsepower requirement. **DO NOT** add restriction to supply line. If pump was incorrectly selected, a smaller impeller may be required or a higher motor horsepower may be required.

If uncertain about pump selection and application, temporarily install an ammeter in the electrical service.

Ammeter Test

WARNING

To avoid electrocution and equipment damage, only a qualified electrician should install the ammeter.

Operate pump under process conditions and check motor amp draw versus nameplate full load rating. If amp draw exceeds motor rating, a system change or pump change is required.

If process conditions and/or liquid changes (higher viscosity, higher specific gravity) recheck motor amp draw.

Contact your authorized Waukesha Cherry-Burrell distributor for assistance.

Operation

Pump must have been correctly installed as described in “Installation” on page 16.

Starting the Pump

The following is the procedure for starting the pump.

1. If pump has the flush seal option, start flow of flush water (approximately 5 US gallons per hour recommended rate) before operating the pump.
2. Prime the pump by flooding the pump casing with liquid **BEFORE** starting pump to avoid damage to pump parts. See “Priming The Pump With The Feed Source Above Pump Level” on page 21 or “Priming The Pump With The Feed Source Below Pump Level” on page 22.
3. Start pump motor.
4. Check the pump to see that liquid is flowing and that all piping connections and seals are leak free.
5. Make sure that the pump is not operating against a closed discharge. Continued operation against a closed discharge will heat liquid in casing to boiling and lead to pump damage.
6. Slowly open discharge valve until desired flow is obtained. Observe pressure gages and if pressure is not attained quickly, stop pump and prime again.

Priming the Pump

Priming The Pump With The Feed Source Above Pump Level

1. Fill supply tank with liquid; open supply line valve (suction) (See Figure 12 item B).
2. Vent any air trapped in supply line or casing by opening the discharge valve. (See Figure 12 item A).

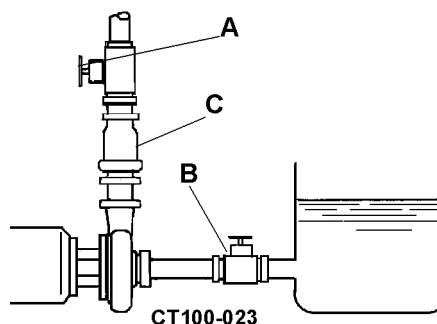

Figure 12 - Pump Below Supply

3. Start pump.

Priming The Pump With The Feed Source Below Pump Level

The pump will not self prime if liquid supply is below pump level. When liquid supply is below pump level an outside source must be provided for priming.

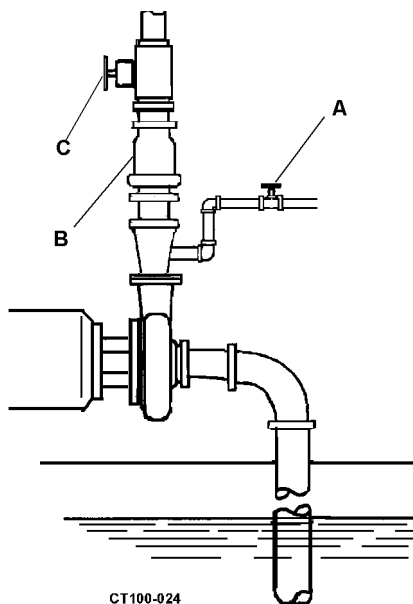

Figure 13 - Pump Above Supply

1. Close discharge valve (See Figure 13 item C) and open air vents.
2. Open valve in outside supply line (See Figure 13 item A) until liquid flows from vent valves.
3. Close vent valves.
4. Close outside supply line.

NOTE: Use a type of check valve system (See Figure 13 item B) to keep supply line and pump casing flooded with liquid. Otherwise the pump must be primed before each operation.

Stopping The Pump

1. To stop pump, shut off power to pump motor.

NOTE: Liquid in system can flow freely through the pump; the pump does not act as a shut off valve.

2. Shut off supply and discharge lines.

Maintenance

Scheduled Maintenance

A routine maintenance program can extend the life of your pump. Keep maintenance records. These will help pinpoint potential problems and causes.

Routine Maintenance

- Check for unusual noise, vibration and bearing temperatures.
- Inspect pump and piping for leaks.
- Check Mechanical Seal area for leakage. No leakage is desired.
- Check backplate gasket for wear/damage.
- Bearing lubrication (See Motor Manufacturer for correct specifications).
- Seal Monitoring.
- Vibration analysis.
- Discharge pressure.
- Temperature monitoring.

Pump Disassembly

1. Shut off product flow to pump and relieve any product pressure.
2. Shut off and lock out power to pump.
3. Disconnect the suction and discharge pipe fittings.

4. Using a wrench remove the seal guard assembly (See Figure 14 item A).

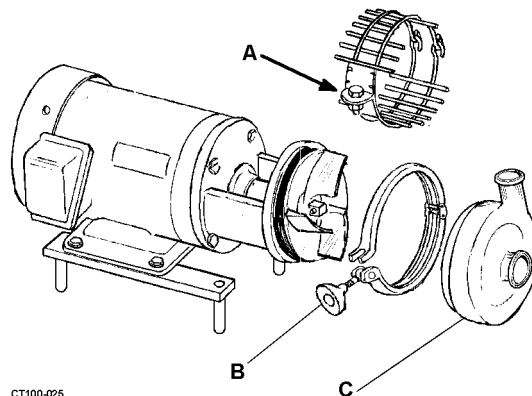

Figure 14 - Casing Assembly

5. Loosen clamp wing nut and swing clamp open. *On C100, remove casing wing nuts.*
6. Inspect clamp saddles and the casing for damage or wear and replace if necessary. (See Figure 14 item B and C).
7. Push back on the impeller and position the retaining pin in the center of the stub shaft. This will allow the impeller to be pulled off the stub shaft.

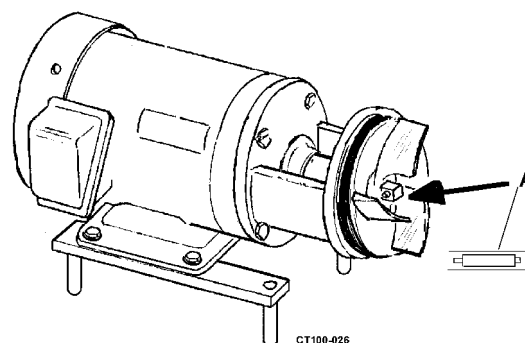
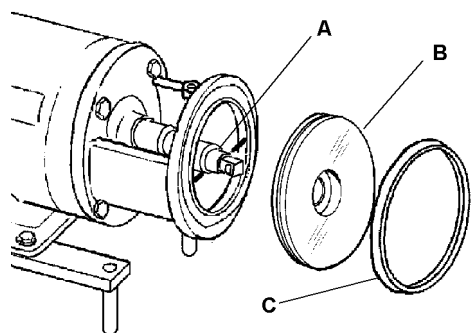

Figure 15 - Impeller Retainer Pin

- Rotate the backplate to disengage the backplate pins from the adapter pins. Remove the backplate with gasket attached (See Figure 16 item B and C), by pulling straight off the adapter. (See Figure 16 item A).



CT100-027

Figure 16 - Backplate Gasket

- Remove the backplate gasket and inspect it for wear and sealing failure.

NOTE: Take care to protect the sealing face and edges of the backplate from nicks and scratches.

- Pull the carbon seal, O-ring, seal cup and spring straight off the stub shaft to remove. (See Figure 17).
- Carefully inspect the O-ring (See Figure 17 item D) and the carbon seal (See Figure 17 item E) for signs of abrasions, cuts or other wear that could cause leakage.

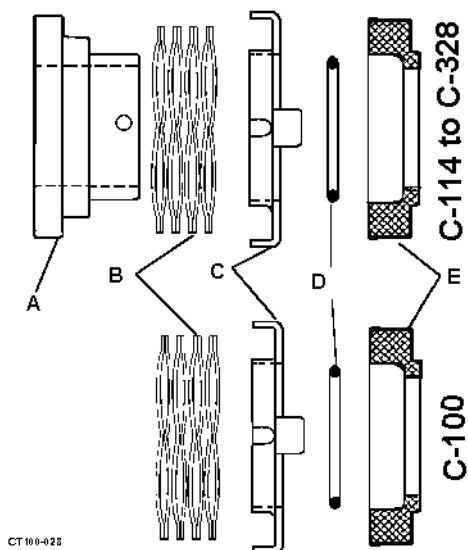

CT 100-028

Figure 17 - Seal Arrangement

NOTE: When the extension end of the carbon seal is less than 1/32", (See Figure 18 item A) replace seal.

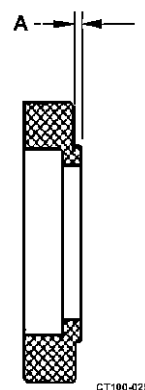

CT100-029

Figure 18 - Carbon Seal Measurements

- After cleaning, inspect the seal, O-ring and gasket again. Replace as necessary.

- Remove the water cascade attachment from the adapter if included. (See Figure 19 item A). Remove the rubber shaft deflector (See Figure 19 item B) by pulling it straight off the stub shaft. Examine it for tearing, loose fit or other defects that would allow liquid leakage into the motor along the shaft.

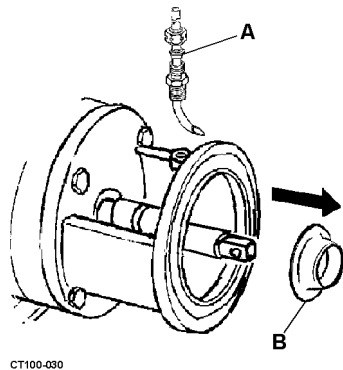

Figure 19 - Removal of Cascade System

Replacing Motor

- To replace or service motor, disassemble the pump as outlined in “Pump Disassembly” on page 23.
- Remove the bolts securing the adapter (See Figure 20 item A and B) to the motor frame and remove the adapter.

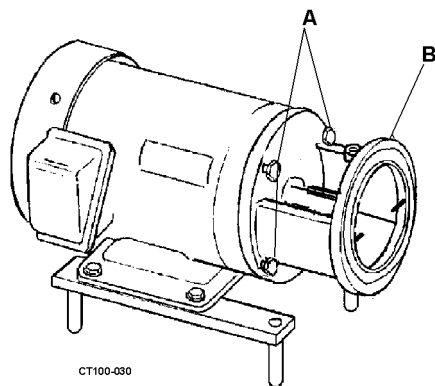

Figure 20 - Removing the Adaptor

- Loosen the two (2) set screws securing the stub-shaft to the motor shaft (See Figure 21 item A and B). Carefully remove the stub-shaft. The stub-shaft is a tight fit, but can be removed by applying pressure around the periphery of the shaft with a pry-bar.

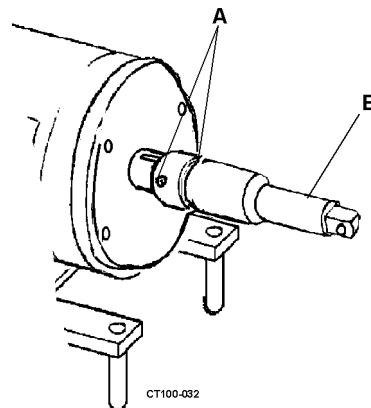

Figure 21 - Stub Shaft Removal

NOTE: Examine the shaft sealing surfaces for nicks or scratches which can cause excessive O-ring wear or leaking.

- Remove the bolts securing the motor to the mounting brackets. Bolt new motor to the mounting brackets.

NOTE: Motor maintenance, repair and wiring are not covered in this manual. For specific information contact the motor manufacturer.

- If required, level the motor by adjusting the legs individually and secure them in place with the set screws. See “Pump Leveling” on page 16.

Installing the Adaptor

1. Install the adapter to the motor, with the drain cavity at the bottom. Insert the four bolts to secure the adapter to the motor. Tighten the bolts. (See Figure 22 item A).

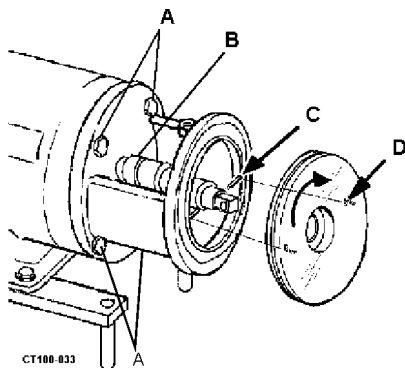

Figure 22 - Adaptor Installation

2. Install the key in the motor shaft.
3. Place the stub-shaft assembly onto the motor shaft. (See Figure 22 item B). **Do not tighten the shaft set screws.**
4. Install the backplate on the adaptor and rotate until the backplate pins engage the adaptor pins, (See Figure 22 item D and C) assuring solid contact of the backplate to the adaptor.
5. Rotate the stub shaft until the impeller retaining hole is in a horizontal position. Insert the impeller retainer pin, and center it in the stub-shaft.
6. Slide the impeller on the shaft. Hold the impeller tight against the shoulder in the shaft and rotate the shaft one-quarter turn until the impeller pin engages with the impeller. See Figure 23.

Stub Shaft Adjustment

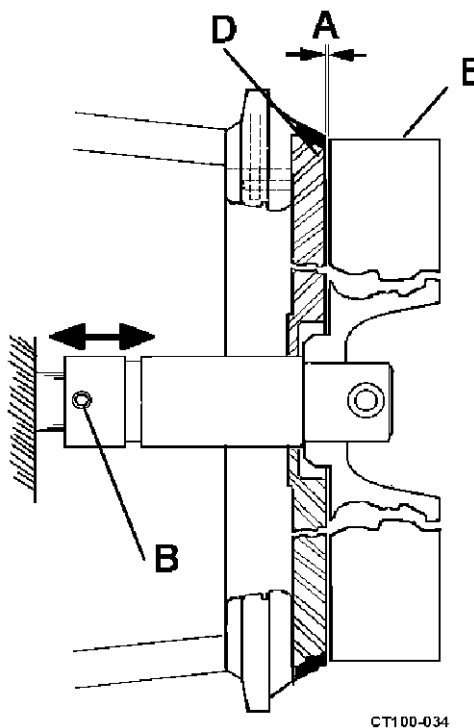

Figure 23 - Setting Backplate/Impeller Clearance

NOTE: For Models C-114 through C-328 See “Stub Shaft Adjustment (Models C-114 through C-328)” on page 27.

1. Place a $0.060 \pm .010$ " (1.52 mm $\pm .25$ mm) Feeler Gauge between the front face of the backplate and the impeller. (See Figure 23 item A).
2. Push the stub-shaft/impeller assembly toward the motor until the impeller (See Figure 23 item E) rests against the Feeler Gauge.
3. Tighten the two set screws on the stub-shaft. (See Figure 23 item B).
4. Check with at Feeler Gauge that the clearance between rear face of the impeller and the front (inside) face of the backplate

is $0.060 \pm .010$ " (1.52 mm \pm .25 mm) (See Figure 23 item A).

5. Remove the impeller retainer pin, impeller and the backplate.
6. Slide the deflector (large diameter end first) onto the shaft until it seats in the shaft groove. (See Figure 24 item A).

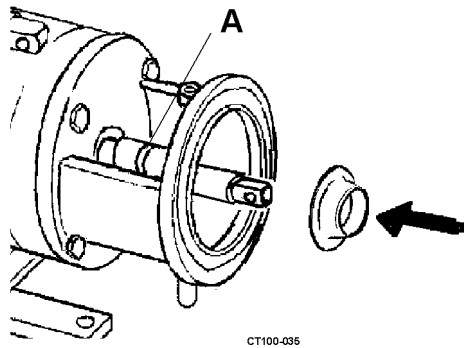

Figure 24 - Installing Deflector

NOTE: If the deflector can not be forced on with the fingers, use a blunt tool to tap it evenly into place.

Stub Shaft Adjustment (Models C-114 through C-328)

1. Slide the seal drive collar onto the stub shaft as shown in Figure 24.
- Use the "A" and "B" dimensions in the Seal Chart to properly locate the drive collar on the stub shaft. See Figure 25. Tighten the set screws to secure in place.

Table 7: Seal Chart

Model	A	B
C-114	9/16" 14.2mm	1- 7/16" 36.5 mm
C-216	9/16 14.2mm	1-23/32" 43.6 mm
C-218	9/16 14.2mm	1-41/64" 41.6 mm
C-328	9/16 14.2mm	1-41/64" 41.6 mm

NOTE: C-100 pump does not require drive collar.

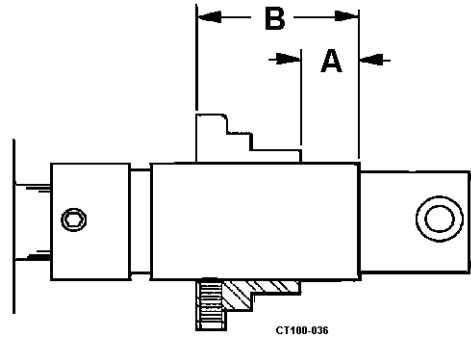

Figure 25 Drive Collar Adjustment

2. See Figure 25. Assemble the spring (item B), seal cup (item C), o-ring (item D) and Carbon Seal (item E), and install as a unit, taking care that slot in seal cup aligns with the pin on shaft. Gentle pressure on the o-ring will overcome resistance on the shaft.

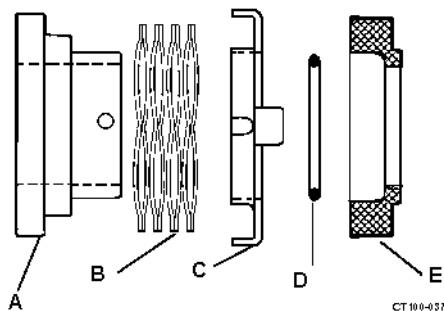

Figure 26 - Carbon Seal

NOTE: Do not lubricate seals with any type of oil or grease, the seal faces will be lubricated by the product being pumped.

3. Assemble the gasket to the backplate.
4. Install the backplate on the adapter. Check that the seal cup slot is engaged with the pin on the drive collar. See Figure 26.
5. Rotate the backplate until the backplate pins engage the adapter pins. (See Figure 27 item A and B).

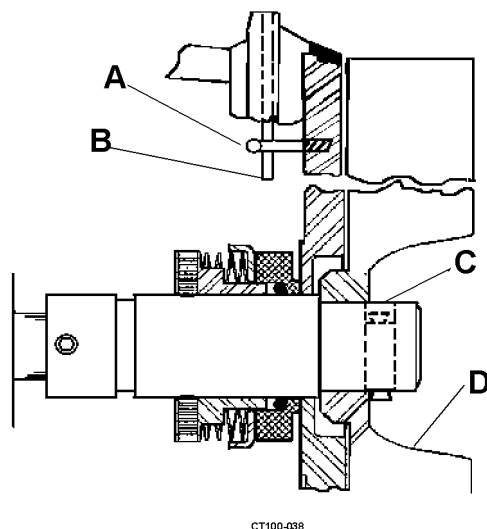

Figure 27 - Backplate Installation

6. Rotate the shaft until the pin hole in the end is in a horizontal position. Insert the impeller pin (See Figure 27 item C), center

it in the shaft end and slide the impeller (See Figure 27 item D) on the shaft.

- Hold the impeller tight against the stub shaft and rotate the shaft one-fourth turn until the impeller pin drops and secures the impeller.
7. Place the casing over the impeller/backplate, close and tighten the clamp. See Figure 28.

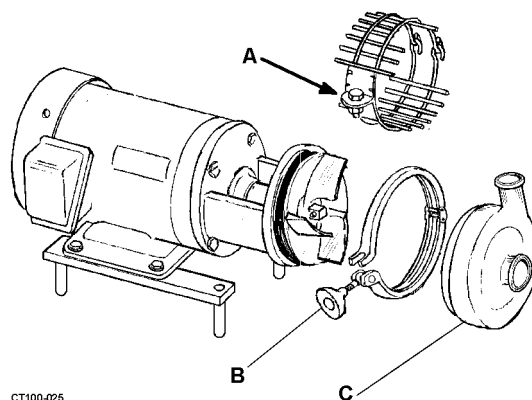

Figure 28 - Casing Clamp Guard Assembly

8. Assemble the cascade water fitting if included. Install seal guard and tighten in place. Assemble the suction line and the discharge line to the casing.

NOTE: Check for strain or misalignment of piping to the casing. Re-adjust the casing ports and/or entire motor leveling as necessary.

Seal Repair

Type E Water Cooled Balanced Double Seal

The Type E seal consists of two carbon seals inside a stuffing box, which is attached to the backplate. Its sealing action is the same as the external balanced seal.

This seal design is used in applications where a vacuum tight, cool operating seal is required.

It is recommended that periodic inspection of all parts of the pump be made to prevent malfunctions caused by worn or broken parts.

NOTE: Disassembly for repair is the same procedure as for cleaning.

Seal Servicing

1. Disconnect the water inlet and outlet from the stuffing box.
2. With a wrench of appropriate size, remove seal guard assembly.
3. Remove the casing and clamp assembly.
4. Remove the four screws that retain the follower to the stuffing box.
5. Slide the stuffing box and backplate assembly forward off of the stub shaft.
6. Remove the inboard carbon seal, seal o-ring, cup and the seal spring from the shaft.
7. Loosen the two set screws and remove the drive collar.
8. The remaining carbon seal, seal o-ring, cup and the follower may now be removed from the shaft.

Installing E Seal

1. Install the backplate, gasket, and casing. See Figure 27 on page 28.
2. Install and tighten casing clamp.

3. Scribe a mark on the shaft at location "A" behind the backplate. See Figure 29.

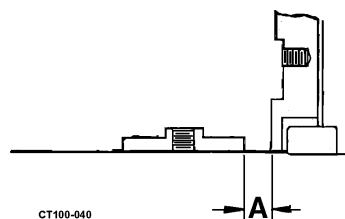

Figure 29 - Drive Collar to Backplate Dimension

Table 8: Callout dimensions for Figure 29

MODEL	A DIMENSIONS
114	5/16" (7.9 mm)
216	23/64" (9.12 mm)
218	23/64" (9.12 mm)
328	23/64" (9.12 mm)

4. Remove casing clamp, casing, and backplate.
5. Slide the deflector, follower, one carbon seal, one seal o-ring, one seal cup, and drive collar onto the shaft.

NOTE: Drive collar location is critical.

6. Locate drive collar in relation to the scribe mark and secure to the shaft with the set screws. See Figure 29.
7. Install the seal spring, seal cup, seal o-ring and seal onto the shaft. See Figure 31 on page 31.
8. Be sure the spring is seated in each cup and the drive ear on each seat cup is not in alignment with the drive pins on the drive collar.
9. Slide the stuffing box and backplate assembly over the shaft and seal parts.

10. Secure the follower to the stuffing box using four screws.
 11. Assemble seal guard and tighten nut.
 12. Attach the water inlet and outlet to the stuffing box.
- Two 1/8" NPT water connections are provided on the stuffing box. They are spaced at 90° from each other and should be located at 45° to vertical when assembling the pump. Flush water must enter one of these connections and exit through the other.

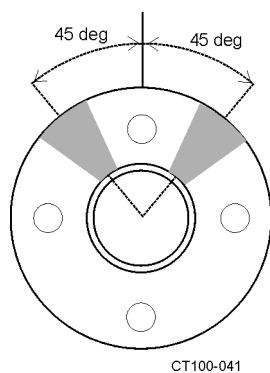
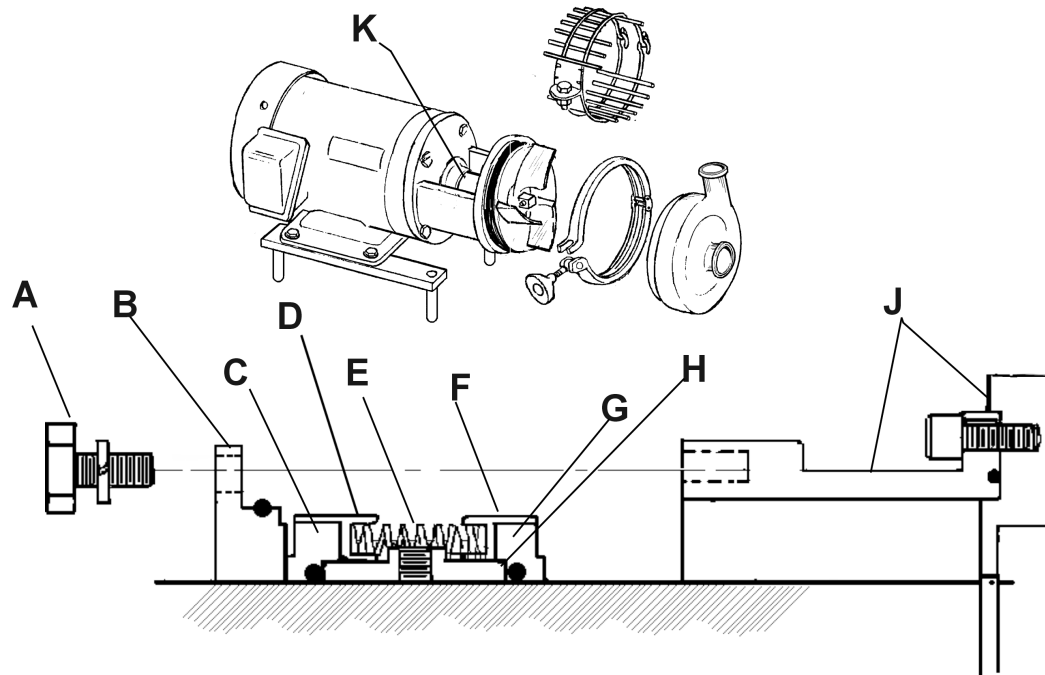

Figure 30 - Water Connection Locations

NOTE: Water must be piped through the stuffing box to keep the seal cool and vacuum tight.

13. The amount of water used will vary depending on the operating temperature of the pump. In vacuum applications 10 drops per minute discharge is recommended.
- Approximately 3 gallons per hour is required to maintain seal temperature at 100° F when the product temperature is 175°F.



CT100-038

Figure 31 - Parts Stack for Stuffing Box

Table 9: Callouts For Figure 31

A. Four Screws	F. Cup
B. Follower	G. Seal
C. Seal	H. Drive Collar
D. Cup	J. Stuffing Box and Backplate
E. Spring	K. Stuffing Box

Parts Lists

C-100

ITEM	DESCRIPTION	PART #	QTY
1	Casing, 1.5" x 1"	60000	1
2	Impeller, 3.68"	60026	1
6A	Shaft Set Screw	30-435	2
6	Stub Shaft-56C Frame	60050	1
	Stub Shaft- 143TC -145TC Frame	60051	1
11	Backplate	60597	1
*24	Impeller Retainer	60039	1
40	Deflector	60042	1
71	Adapter 56C Frame	60596	1
	Adapter 143/145TC Frame	60600	1
71B	Adapter Mounting Bolt, 56C Frame	30-186	4
75K	Wing Nut	60083	2
*80	Carbon Seal	60084	1
*80A	Cup	60088	1
*80B	Seal O-Ring, Buna N	N70214	1
	Seal O-Ring, Fluoroelastomer	V70214	1
*80C	Spring	60091	1
*90	Casing O-Ring, Buna N	60598	1
	Casing O-Ring, Fluoroelastomer	60599	1

C-100

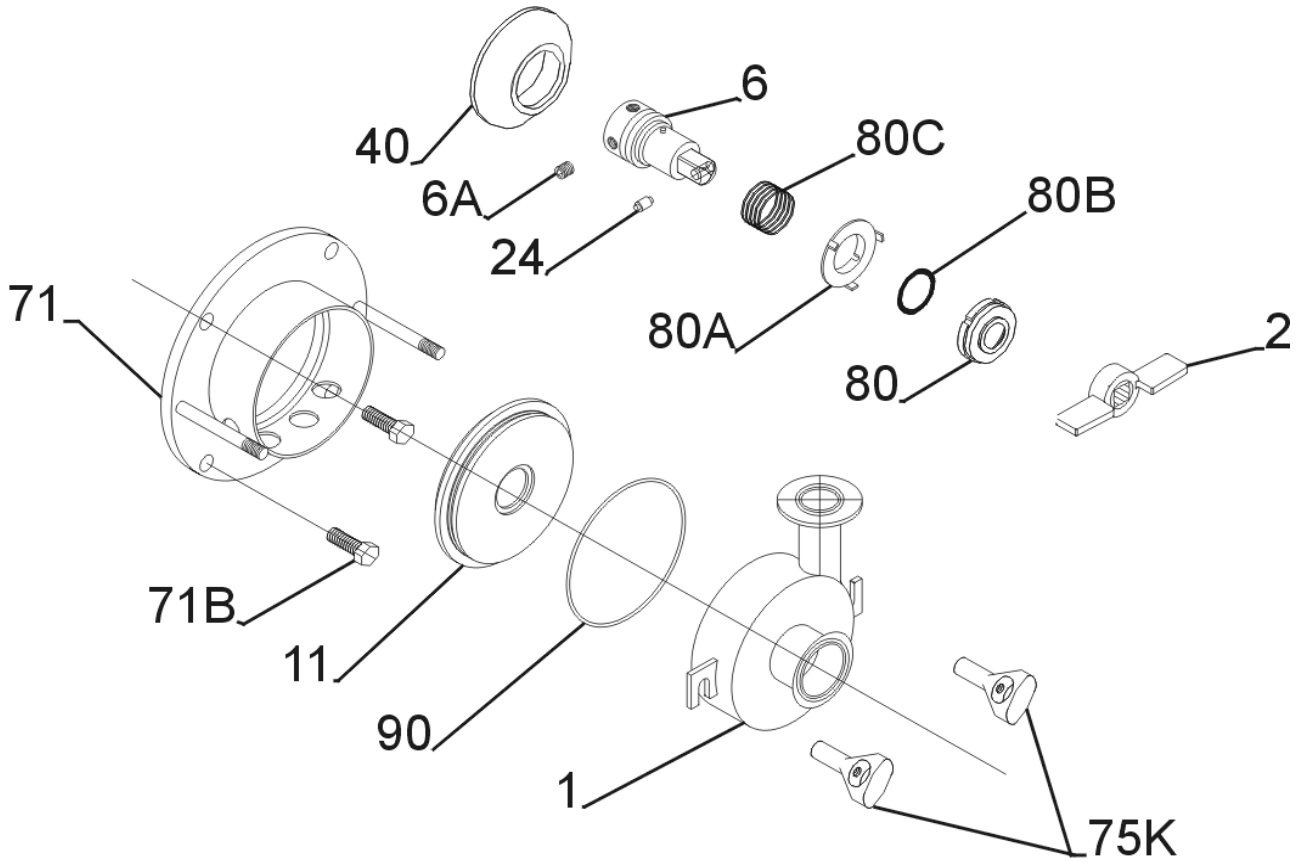

CT100-053

Shown with the standard type "D" seal

C-114

ITEM	DESCRIPTION	PART #	TRI-CLOVER PART #	QTY
1	Casing, 1-1/2" x 1-1/2"	60001	S114M-01C-316L	1
	Casing, 2" x 1-1/2"	60002	S214M-01C-316L	1
2	Impeller, 4.0"	60027	S 114-02C-316L	1
6A	Shaft Set Screw	30-436	SC1305A-SS	2
6E	Stub Shaft, 56C Frame	60052	C 114E56T-06-316L	1
	Stub Shaft, 143TC-145TC Frame	60053	C114E14T-06-316L	1
	Stub Shaft, 180TC Frame 6.25" length	60054R2	C 114E18T-06-316L	1
11	Backplate	60010	114D-11-316	1
11F	Backplate Pin	60013	216D-11-1-S	2
*24	Impeller Retainer	60039	114D-24B-316L	1
40	Deflector, 56C-145TC Frame	60042	US 114D66-40-U	1
	Deflector, 180 TC Frame	60043	114D 18T-40	1
71	Adapter, 56C-140TC Frame	60748	114E56T-71C-C	1
	Adapter, 182TC-184TC Frame	60749	114E-18T-71C-C	1
71A	Adapter Pin	30-434	216D-71A-1-S	2
71B	Adapter Mounting Bolt, 56C-140TC Frame	30-351	SC1512H-SS	4
	Adapter Mounting Bolt, 180TC Frame	30-241	SC1710H-SS	4
75	Clamp Assembly	60080	S 114-75AR-S	1
75K	Wing Nut	60083	13MHHS-1.5-03-S	1
*80	Carbon Seal	60085	114E-80-1A	1
*80A	Cup	60088	114D-80-3P	1
*80B	Seal O-Ring, Buna N	N70210	60C-3-34A-U	1
	Seal O-Ring, Fluoroelastomer	V70210	60C-3-34A-SFY	1
*80C	Spring	60091	114D-80-4	1
80K	Set Screw	30-629	SC905A-SS	2
*80L	Drive Collar	60094R1	SP 114D-23P-316L	1
*90	Casing Gasket, Buna N	60099	S 114-90A-U	1
	Casing Gasket, Fluoroelastomer	60100		1
131	Guard Assembly -56C-140TC Frame	60782	C114-56T-131A-S	1
	Guard Assembly -180TC Frame	60783	C114-18T-131A-S	1

C-114

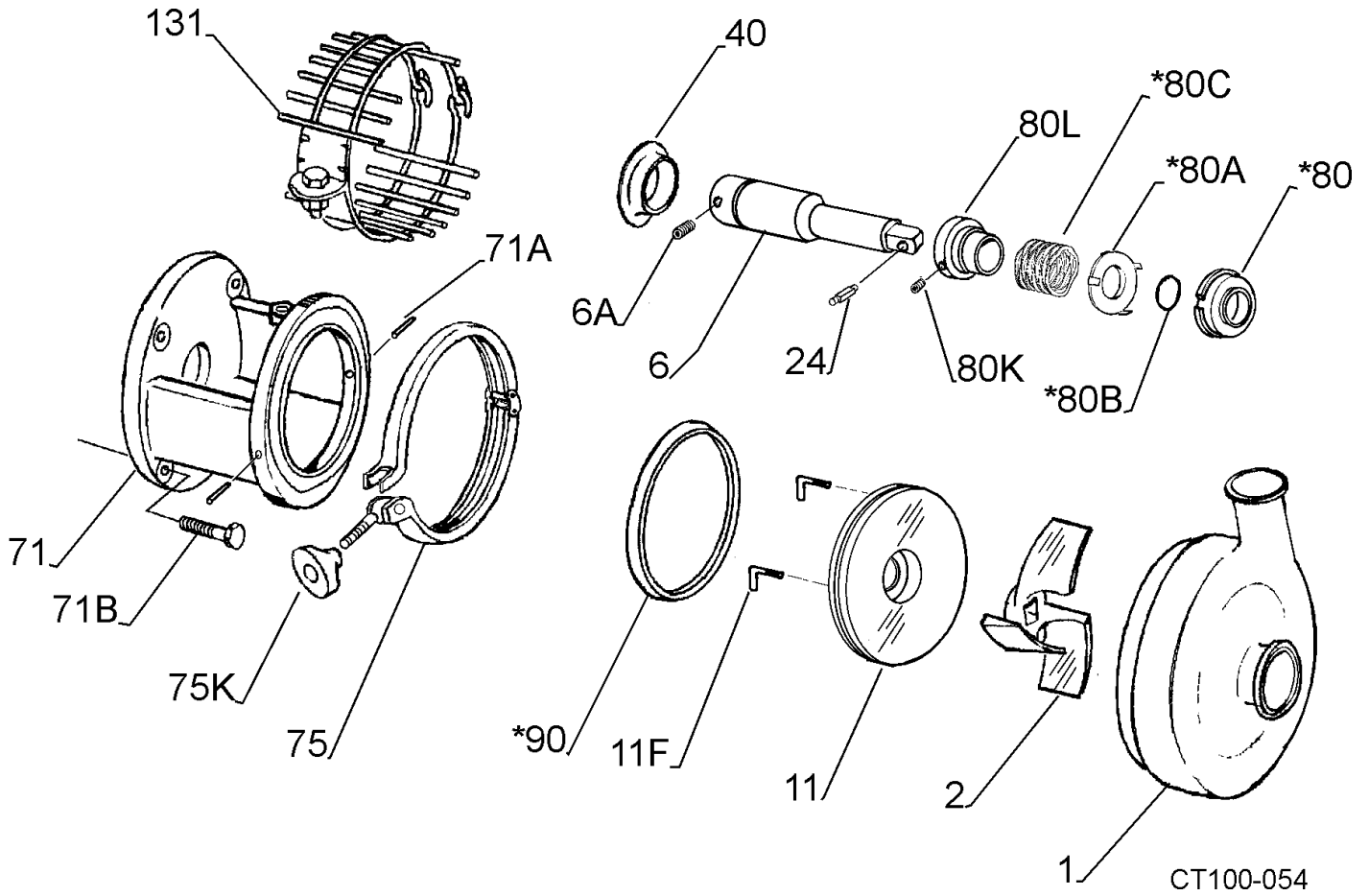

Shown with standard type "D" Seal

For other optional seals see "Type "E" Water Cooled Double Balanced Seal Option" on page 42 and "Type "DG" Seat Assembly Option" on page 44

C-216

ITEM	DESCRIPTION	PART #	QTY
1	Casing, 2" x 1-1/2"	60003	1
	Casing, 2-1/2" x 1-1/2"	60004	1
2	Impeller, 6.0"	60028	1
6A	Shaft Set Screw	30-38	2
6E	Stub Shaft, 56C Frame	60055	1
	Stub Shaft, 140TC Frame	60056	1
	Stub Shaft, 180TC Frame	60057	1
	Stub Shaft, 210TC Frame	60058R3	1
	Stub Shaft, 250TC Frame	60059R3	1
11	Backplate	60011	1
11F	Backplate Pin	60013	2
*24	Impeller Retainer	60040	1
40	Deflector, 56C-184TC Frame	60044	1
	Deflector, 213TC-215TC Frame	60045	1
	Deflector, 254TC-256TC Frame	60046	1
71	Adapter, 56C-145TC Frame 304SS	60750	1
	Adapter, 182TC-184TC Frame 304SS	60751	1
	Adapter, 213TC-215TC Frame 304SS	60752	1
	Adapter, 254TC-256TC Frame 304SS	60753	1
71A	Adapter Pin	30-434	2
71B	Adapter Mounting Bolt, 56C-1450TC Frame	30-351	4
	Adapter Mounting Bolt, 180TC-250TC Frame	30-241	4
75	Clamp Assembly	60081	1
75K	Wing Nut	60083	1
*80	Carbon Seal	60086	1
*80A	Cup	60089	1
*80B	Seal O-Ring, Buna N	N70216	1
	Seal O-Ring, Fluoroelastomer	V70216	1
*80C	Spring	60092	1
80K	Set Screw	30-178	2
80L	Drive Collar	60095R1	1
*90	Casing Gasket, Buna N	60101	1
	Casing Gasket, Fluoroelastomer	60102	1
131	Guard Assembly -56C-140TC	60784	1
	Guard Assembly -180TC	60785	1
	Guard Assembly -210TC	60786	1
	Guard Assembly -250TC	60787	1

C-216

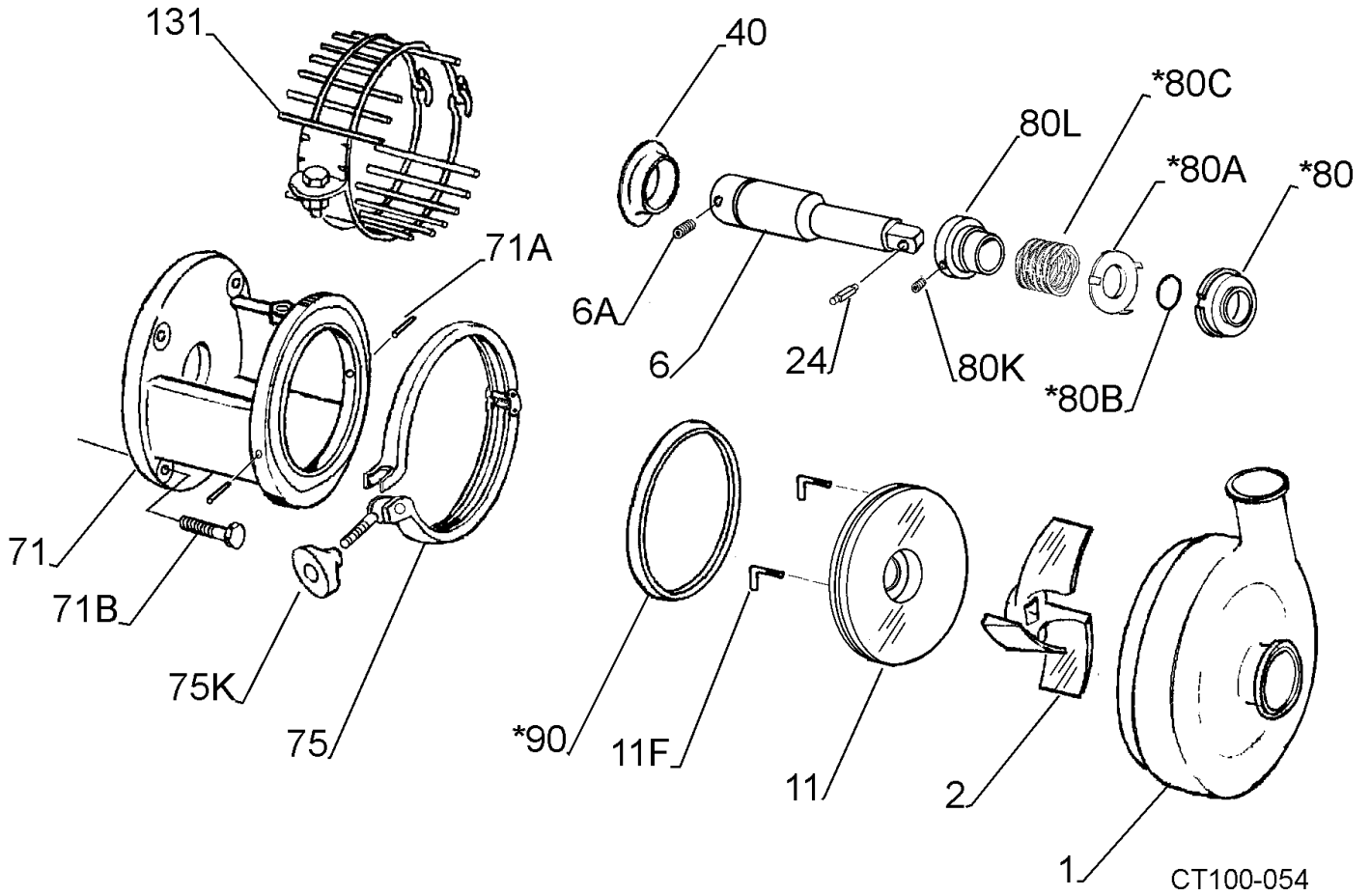

Shown with standard type "D" Seal

For other optional seals see "Type "E" Water Cooled Double Balanced Seal Option" on page 42 and "Type "DG" Seat Assembly Option" on page 44

C-218

ITEM	DESCRIPTION	PART #	QTY
1	Casing, 2" x 1-1/2"	60005R2	1
	Casing, 3" x 1-1/2"	60006	1
2	Impeller, 8.0"	60029	1
6A	Set Screw, 140TC-280TC Frame	30-38	2
6E	Stub Shaft, 140TC Frame	60060	1
	Stub Shaft, 180 TC Frame	60061	1
	Stub Shaft, 210 TC Frame	60062	1
	Stub Shaft, 250 TC Frame	60063	1
	Stub Shaft, 280 TS	60064	1
11	Backplate	60012	1
11F	Backplate Pin	60013	2
*24	Impeller Retainer	60041	1
40	Deflector, 140/180TC Frame	60047	1
	Deflector, 210 TC Frame	60046	1
	Deflector, 280 TC Frame	60048	1
71	Adapter, 140TC Frame 304SS	60754	1
	Adapter, 180TC Frame 304SS	60755	1
	Adapter, 210TC Frame 304SS	60756	1
	Adapter, 250TC Frame 304SS	60757	1
	Adapter, 280TC Frame 304SS	60758	1
71A	Adapter Pin	30-434	2
71B	Adapter Mounting Bolt, 143TC-145TC Frame	30-351	4
	Adapter Mounting Bolt, 182TC-286TC Frame	30-241	4
75	Clamp Assembly	60082	1
75K	Wing Nut	60083	1
*80	Carbon Seal	60087	1
*80A	Cup	60090	1
*80B	Seal O-Ring, Buna N	N70222	1
	Seal O-Ring, Fluoroelastomer	V70222	1
*80C	Spring	60093	1
80K	Set Screw	30-178	2
*80L	Drive Collar	60096R1	1
*90	Casing Gasket, Buna N	60103	1
	Casing Gasket, Fluoroelastomer	60104	1
131	Guard Assembly -140TC Frame	60788	1
	Guard Assembly -180TC Frame	60789	1
	Guard Assembly -210TC Frame	60790	1
	Guard Assembly -250TC Frame	60791	1
	Guard Assembly -280TC Frame	60792	1

C-218

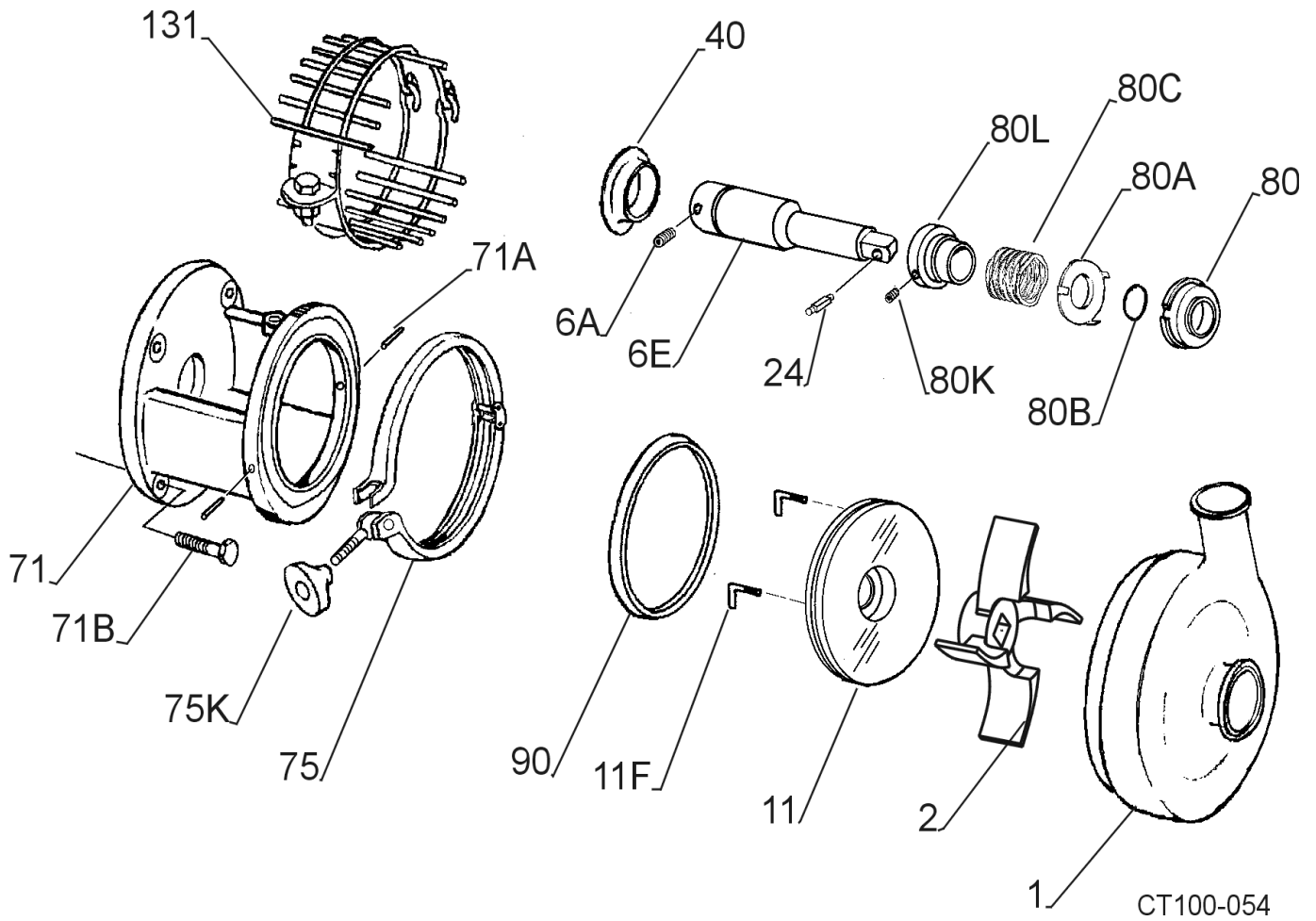

C-328

ITEM	DESCRIPTION	PART #	QTY
1	Casing, 3"x2"	60007	1
	Casing, 4"x2"	60008	1
2	Impeller, 8.0"	60030	1
6A	Shaft Set Screw, 182TC-184TC Frame	30-38	2
	Shaft Set Screw, 210TC Frame	30-38	2
6E	Stub Shaft, 180TC Frame	60061	1
	Stub Shaft, 210TC Frame	60062	1
	Stub Shaft, 250TC Frame	60063	1
	Stub Shaft, 280TC Frame	60064	1
	Stub Shaft, 320TC Frame	60065	1
11	Backplate	60012	1
11F	Backplate Pin	60013	2
*24	Impeller Retainer	60041	1
40	Deflector, 180 Frame	60047	1
	Deflector, 210TC Frame	60046	1
	Deflector, 280TC Frame	60048	1
	Deflector, 320TC Frame	60049	1
71	Adapter, 180TC Frame 340 SS	60755	1
	Adapter, 210TC Frame 340 SS	60756	1
	Adapter, 250TC Frame 340 SS	60757	1
	Adapter, 280TC Frame 340 SS	60758	1
	Adapter, 320TC Frame 340 SS	60759	1
71A	Adapter Pin	30-434	2
71B	Adapter Mounting Bolt, 180TC Frame	30-241	4
	Adapter Mounting Bolt, 320TC Frame	30-438	4
75	Clamp Assembly	60082	1
75K	Wing Nut	60083	1
80	Carbon Seal	60087	1
*80A	Cup	60090	1
*80B	Seal O-Ring, Buna N	N70222	1
	Seal O-Ring, Fluoroelastomer	V70222	1
*80C	Spring	60093	1
80M	Set Screw	30-178	2
*80L	Drive Collar	60096R1	1
*90	Casing Gasket, Buna N	60103	1
	Casing Gasket, Fluoroelastomer	60104	1
131	Guard Assembly -180TC Frame	60789	1
	Guard Assembly -210TC Frame	60790	1
	Guard Assembly -250TC Frame	60791	1
	Guard Assembly -280TC Frame	60792	1
	Guard Assembly -320TC Frame	60793	1

C-328

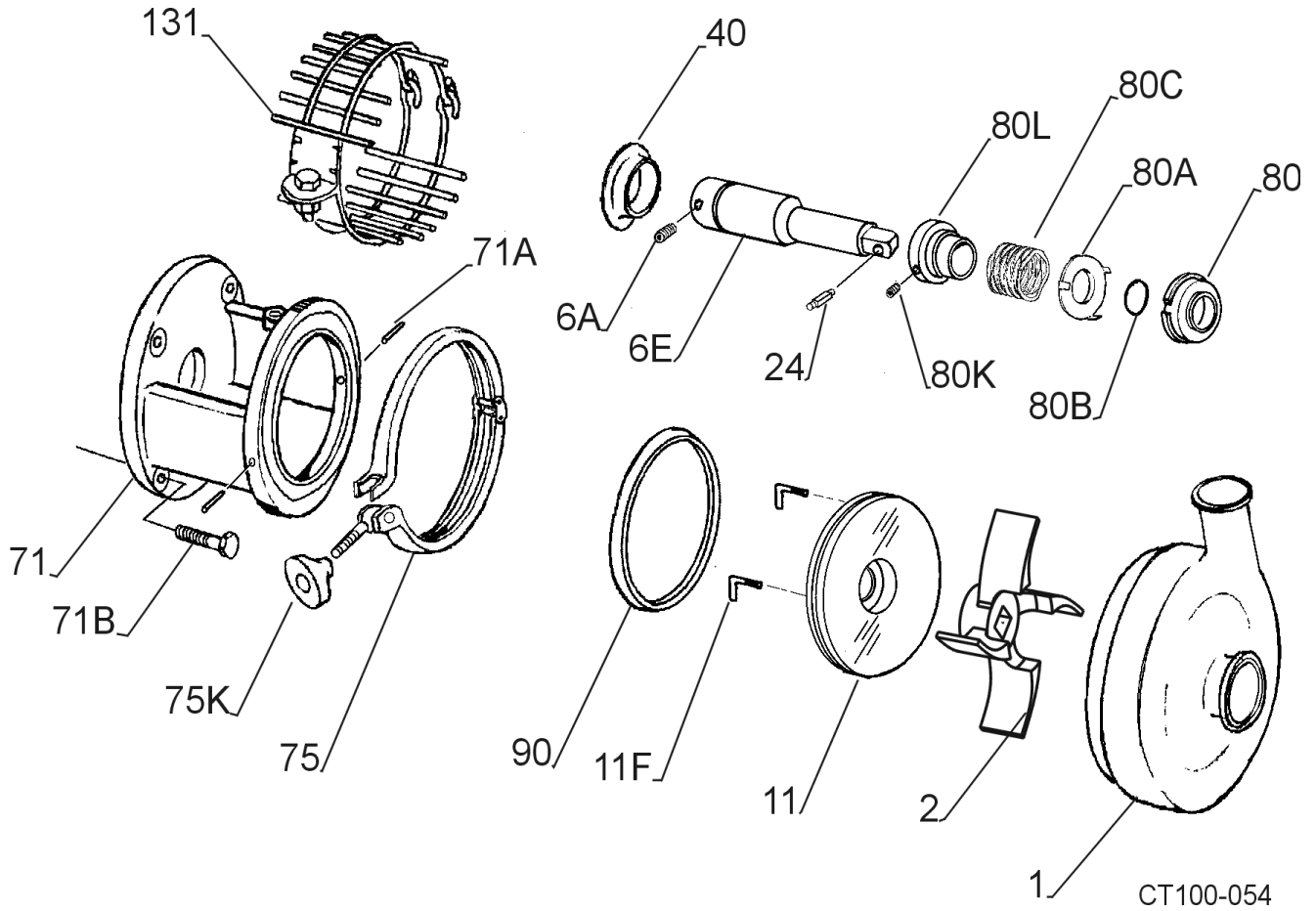

Type "E" Water Cooled Double Balanced Seal Option

ITEM	DESCRIPTION	PART #	TRI-CLOVER PART #	QTY
11B	Backplate (E) C-114	60487	114E-11B-136	1
	Backplate (E) C-216	60488	216E-11B-136	1
	Backplate (E) C-218/328	60489	328E-11B-136	1
17	Follower (E) C-114	60490	114E-17A-136	1
	Follower (E) C-216	60491	216E-17A-136	1
	Follower (E) C-218/328	60492	328E-17-136	1
17A	Machine Screw (E) C-114	30-587	SC1106E-SS	4
	Machine Screw (E) C-216/218/32	30-29	SC1308H-SS	4
17B	O-Ring, Buna (E) C-114	N70033	17-106-U-25	1
	O-Ring, Buna (E) C-216	N70034	17-275-U	1
	O-Ring, Buna (E) C-218/328	N70038	17-274-U	1
17C	Lockwasher	43-15	LWA1300-SS	4
80	Seal Carbon (110 - 114)	60085	114E-80-1A	2
	Seal Carbon (216 - 210)	60086	216E-80-1A	2
	Seal Carbon (218 - 328)	60087	328E-80-1A	2
80B	O-Ring, Buna (E) C-114	N70210	60C-3-34A-U	2
	O-Ring, Buna (E) C-216	N70216	01-1165-19-U	2
	O-Ring, Buna (E) C-218/328	N70222	S328-80-2-U	2
80G	Cup (E) C-114	60493	114E-80-3P	2
	Cup (E) C-216	60494	216E-80-3P	2
	Cup (E) C-218/328	60495	328E-80-3P	2
80H	Spring (E) C-114	60496	114E-80-4A	1
	Spring (E) C-216	60497	216E-80-4A	1
	Spring (E) C218/328	60498	328E-80-4A	1
80J	Drive Collar (E) C-114	60499	114E-23-316L	1
	Drive Collar (E) C-216	60500	216E-23-316L	1
	Drive Collar (E) C-218/328	60501	328E-23-316L	1
80K	Set Screws (E) C-114	30-629	SC903A-SS	2
	Set Screws (E) C-216/218/328	30-589	SC1103A-SS	2
83C	Stuffing Box (E) C-114	60502	114E-83B-316	1
	Stuffing Box (E) C-216	60503	216E-83B-316	1
	Stuffing Box (E) C-218/328	60504	328E-83B-316	1
83D	Machine Screws (E) C-114	30-131	SC904E-SS	4
	Machine Screws (E) C-216	30-587	SC1106E-SS	4
	Machine Screws (E) C-218/328	30-590	SC1308E-SS	4
83E	O-Ring, Buna (E) C-114	N70034	17-275-U	1
	O-Ring, Buna (E) C-216	N70037	17-122-U	1
	O-Ring, Buna (E) C-218/328	N70153	17-153-U	1

Type "E" Water Cooled Double Balanced Seal Option

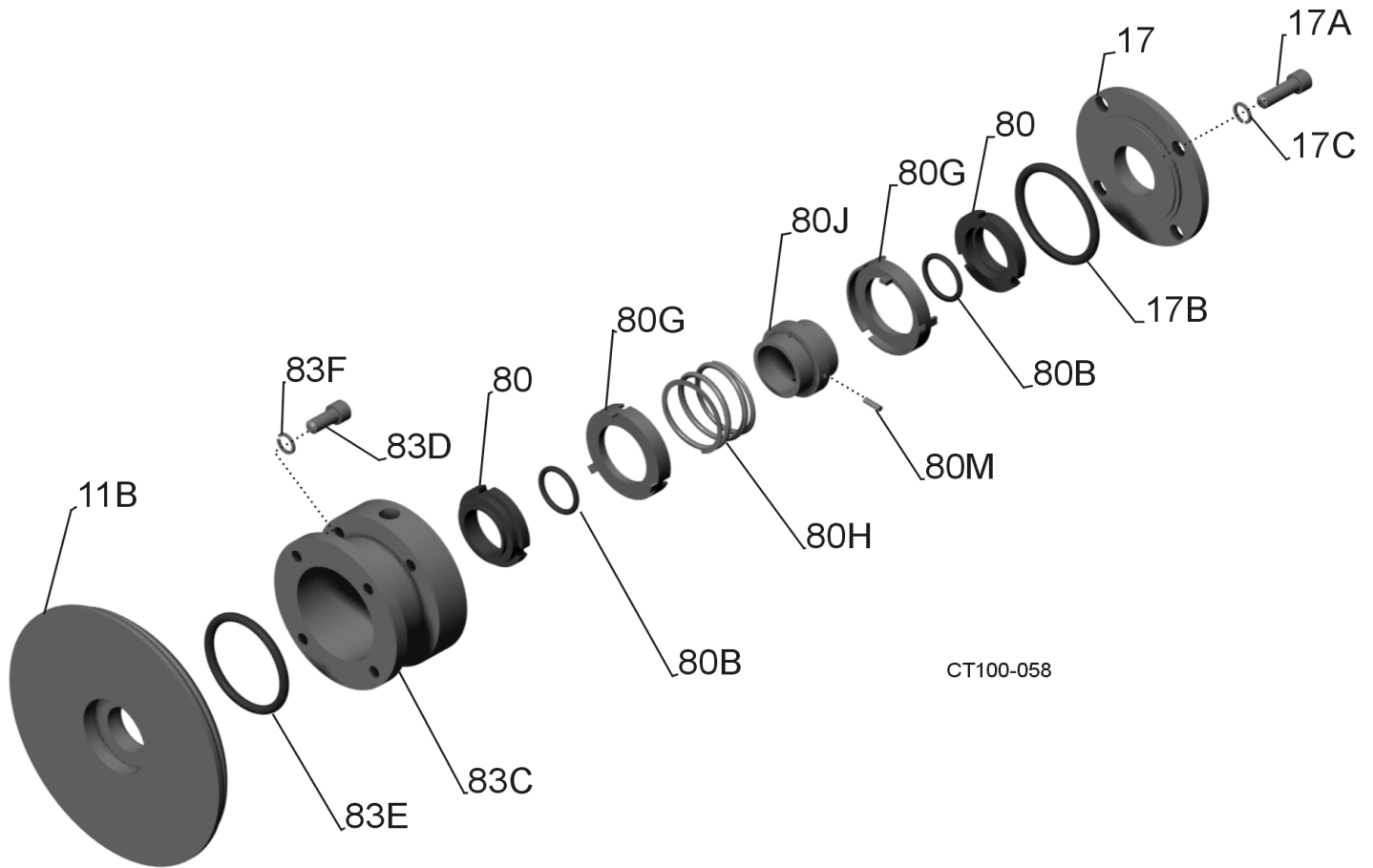

Type "DG" Seat Assembly Option

ITEM	DESCRIPTION	PART #	TRI-CLOVER PART #	QTY
11H	C-114 Backplate	60481	SP114G-11-316L	1
	C-216 Backplate	60482	SP216G-11-316L	1
	C-218 Backplate	60483	SP328G-11-316	1
	C-328 Backplate	60483	SP328G-11-316	1
17J	C-114 SS Gland Ring	60484	SP114G-17-316L	1
	C-216 SS Gland Ring	60485	SP216G-17-316L	1
	C-218 SS Gland Ring	60486	SP328G-17-316L	1
	C-328 SS Gland Ring	60486	SP328G-17-316L	1
17K	C-114 Bolt/Screw	30-582	SC1110H-SS	4
	C-216 Bolt/Screw	30-525	SC1310H-SS	4
	C-218 Bolt/Screw	30-525	SC1311H-SS	4
	C-328 Bolt/Screw	30-525	SC1311H-SS	4
17M	Lockwasher C114	43-22	LWA-1100-SS	4
	Lockwasher C12-320	43-15	LWA-1300-SS	4
80N	C-114 Seal Seat, Silicon Carbon	113670	SP114G-80-1-1-SC	1
	C-216 Seal Seat, Silicon Carbon	113673	SP216G-80-1-1-SC	
	C-218/328 Seal Seat, Silicon Carbon	113676	SP328G-80-1-1-SC	
	C-114 Seat Seal, Purebide	60374	NONE	1
	C-216 Seat Seal Purebide	60375	NONE	1
	C-218/328 Seal Seat Purebide	60376	NONE	
	C-114 Seat Seal, Ceramic	113671	SP114G-80-1-1-CER	
	C-216 Seat Seal Ceramic	113674	SP216G-80-1-1-CER	
	C-218/328 Seal Seat Ceramic	113677	SP328G-80-1-1-CER	
	C-114 Seat Seal, Tungsten Carbide	113669	SP114G-80-1-1-TC	
	C-216 Seat Seal Tungsten Carbide	113672	SP216G-80-1-1-TC	
	C-218/328 Seal Seat Tungsten Carbide	113675	SP328G-80-1-1-TC	
80P	C-114 PTFE Gasket	60377	SP114G-80-1-2-G	1
	C-216PTFE Gasket	60378	SP216G-80-1-2-G	1
	C-218/328 PTFE Gasket	60379	SP326G-80-1-2-G	1

ITEM	DESCRIPTION	PART #	TRI-CLOVER PART #	QTY
80R	C-110 PTFE Gasket - Inboard	60760	SP114G-80-1-2A-G	1
	C-216 PTFE Gasket - Inboard	60761	SP216G-80-1-2A-G	1
	C-218/328 PTFE Gasket - Inboard	60762	SP326G-80-1-2A-G	1

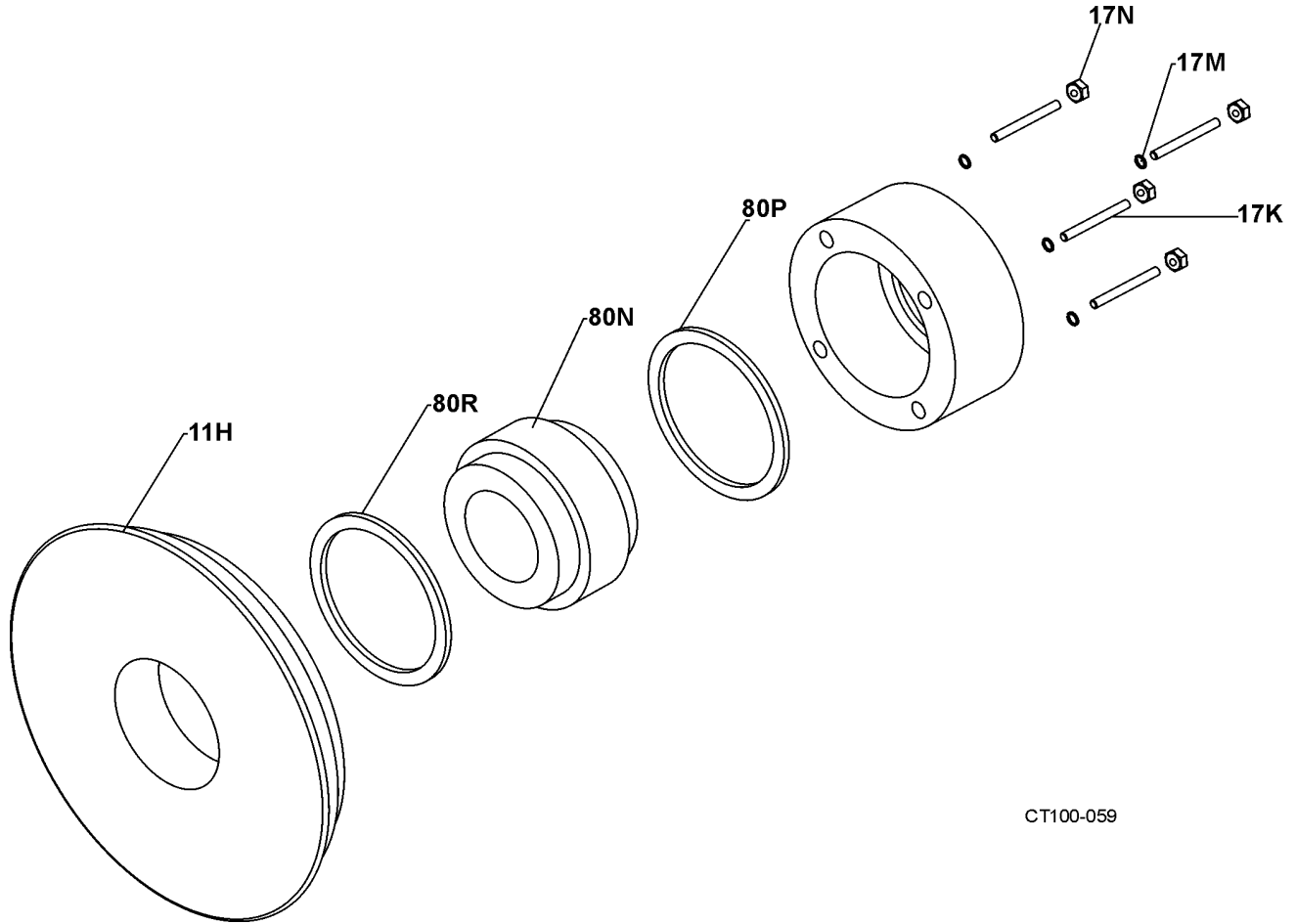

CT100-059

Troubleshooting

PROBLEM	POSSIBLE CAUSE	SUGGESTED ACTION
Not Enough Liquid Delivered.	Pump not primed.	Prime pump. Install a priming system if possible.
	Suction or discharge plugged or closed.	Open suction. If plugged <u>shutdown pump</u> and remove blockage.
	Air leak in supply or at seal area.	Check system for air leaks and repair as necessary. Replace seals if required.
	Wrong direction of rotation.	Adjust motor electrical wiring to correct rotation.
	Discharge head too high.	Lower discharge head until pump can move material without turning to freely causing overload.
	Suction lift too high.	Lower pump in system until the pump is easily supplied with material.
	Speed too slow (low voltage, wrong frequency, wrong motor).	Adjust voltage and frequency. Change motor if necessary.
	Excessive air in material.	Adjust system to remove excess air from material before it reaches the pump.
	Insufficient NPSH (Net Positive Suction Head) available.	Adjust system to provide correct NPSH.
Impeller diameter too small for duty.	Contact your Waukesha Cherry-Burrell Customer Service Representative for sizing information. WCB Customer Service Telephone: 1-800-252-5200 or 262-728-1900	

Not Enough Pressure.	Air leak in supply or at seal area.	Check system for air leaks and repair as necessary. Replace seals if required.
	Wrong direction of rotation.	Adjust motor electrical wiring to correct rotation.
	Speed too slow (low voltage, wrong frequency, wrong motor).	Adjust voltage and frequency. Change motor if necessary.
	Excessive air in material.	Adjust system to remove excess air from material before it reaches the pump.
	Impeller diameter too small for duty.	Contact your Waukesha Cherry-Burrell Customer service representative for sizing information. WCB Customer Service Telephone: 1-800-252-5200 Or 262-728-1900
Motor Overload	Faulty electrical connections.	Check wiring and repair/replace as necessary.
	Unrestricted discharge resulting in too high a flow rate.	Add discharge restriction to lower flow rate.
	Impeller interference.	Disassemble pump and inspect for damage. Remove interference if still present. Replace worn/damaged parts.
	Seal binding.	Disassemble pump and inspect for damage. Check for material crystallization on seals.
	Discharge head too low allowing pump to deliver too much liquid.	Raise discharge head until pump achieves proper resistance to flow.
	Liquid heavier or more viscous than rating.	Contact your Waukesha Cherry-Burrell Customer service representative for sizing information. WCB Customer Service Telephone: 1-800-252-5200 Or 262-728-1900
	Overload heaters too small for motor.	Inspect and replace as necessary.

	Electrical supply, voltage, frequency, incorrect.	Adjust voltage and frequency. Change motor if necessary.
	Impeller diameter too large for duty.	Contact your Waukesha Cherry-Burrell Customer service representative for sizing information. WCB Customer Service Telephone: 1-800-252-5200 Or 262-728-1900
	Defective motor.	Replace motor.

Vibration/Noise.	Pump not level.	Make sure all legs are touching the floor. Level pump.
	Piping not supported.	Support all piping as described in the installation section.
	Starved suction/Supply line blocked.	<u>Shutdown pump</u> and remove blockage.
	Foreign material in pump.	Disassemble pump, remove all foreign material and inspect for damage. Replace worn/damaged parts.
	Starved suction/Insufficient NPSH (Net Positive Suction Head) available.	Adjust system to provide correct NPSH.
	Impeller hub/impeller shaft worn.	Disassemble pump and inspect for damage. Replace worn parts.
	Impeller shaft loose or bent.	Disassemble pump and inspect for damage.
	Impeller out of balance.	Disassemble pump and inspect for damage. Replace impeller.
	Motor bearings worn.	Disassemble motor and inspect for damage. Replace worn parts.
	Starved suction/Supply line too long.	Shorten system supply line.
	Starved suction/Supply line too small.	Install larger supply lines.
	Excessive air in material.	Adjust system to remove excess air from material before it reaches the pump.

Rapid Seal Wear.	Incorrect impeller shaft location; excessive spring loading.	Adjust pump alignment to motor and piping.
	Water Hammer.	Adjust system to reduce air in system and sudden starts or stops in flow.
	Impeller shaft loose or bent.	Disassemble pump and inspect for damage. Replace worn/damaged parts.
	Abrasive product.	Contact your Waukesha Cherry-Burrell Customer service representative for alternate seal information. WCB Customer Service Telephone: 1-800-252-5200 Or 262-728-1900
	Prolonged "dry" running.	Adjust process to insure pump has a continual fresh supply of product during operation.
	Abrasive solids (unfiltered) in flush water supplied to seal.	Use only filtered water in seal flush system.
Seal Leaks	Gasket damaged or worn.	Disassemble pump and inspect for damage.
	Seal not installed correctly.	Disassemble pump and inspect seal for damage (replace if necessary). Install seal correctly and assemble pump.
	Carbon seal worn or damaged.	Disassemble pump and inspect seal for damage (replace if necessary).
	Inlet/Outlet connection loose or no gasket.	Inspect inlet/outlet connection for gasket and tighten connection.
	Casing clamp loose.	Tighten clamp.

NOTES



**Waukesha
Cherry-Burrell**

A Unit of SPX Process Equipment

®

611 Sugar Creek Road • Delavan, WI 53115 USA
Tel: 1.800.252.5200 or (262)728.1900 • Fax: 1.800.252.5012 or (262)728.4904
E-mail: custserv@gowcb.com • Web site: www.gowcb.com
Issued: November 26, 2001 • Revised: April 1, 2003
95-03008